

Figure 6-28.1 - Fabric and Supporting Frame For Inlet Projection

PURPOSE
To prevent sediment from entering a storm drainage system prior to permanent stabilization of the disturbed area draining to the inlet.

CONDITIONS
All storm drain drops that receive runoff from disturbed areas.

DESIGN CRITERIA
Through holes are 2 different categories: high retention and high flow. In areas where BMPs are being used on paved surfaces, or safety is a concern, the potentially negative effects of ponding should be taken into account. In such cases, a high flow BMP is preferred. On unpaved areas where ponding will not cause a safety hazard, high retention shall be taken into account. If high retention is not used in this situation a rationale shall be given on the plan and an unapproved application should apply. Sediment traps must be self-draining unless they are otherwise protected in an approved location that will not present a safety hazard. The drainage area entering the inlet sediment trap shall be no greater than 1 acre. If runoff may bypass the protection, a temporary site should be constructed on the down slope side of the structure. Also, a stone filter ring may be used on the up slope side of the inlet's slow runoff and filter larger soil particles. Refer to *Soil Retention Filter Ring*.

CONSTRUCTION SPECIFICATIONS
Filter Fabric with Supporting Frame
The method of inlet protection is applicable where the inlet drains a relatively flat area (slope no greater than 5%) and shall not apply to inlets receiving concentrated flows, such as in street or highway medians. As shown in Figure 6-28.1, Type S silt fence supported by steel posts should be used. The stakes shall be spaced evenly around the perimeter of the inlet a maximum of 2' apart, and securely driven into the ground, approximately 18\"/>

INLET SEDIMENT TRAP (FILTER FABRIC W/ SUPPORTING FRAME) - (Sd2-F)
N.T.S.

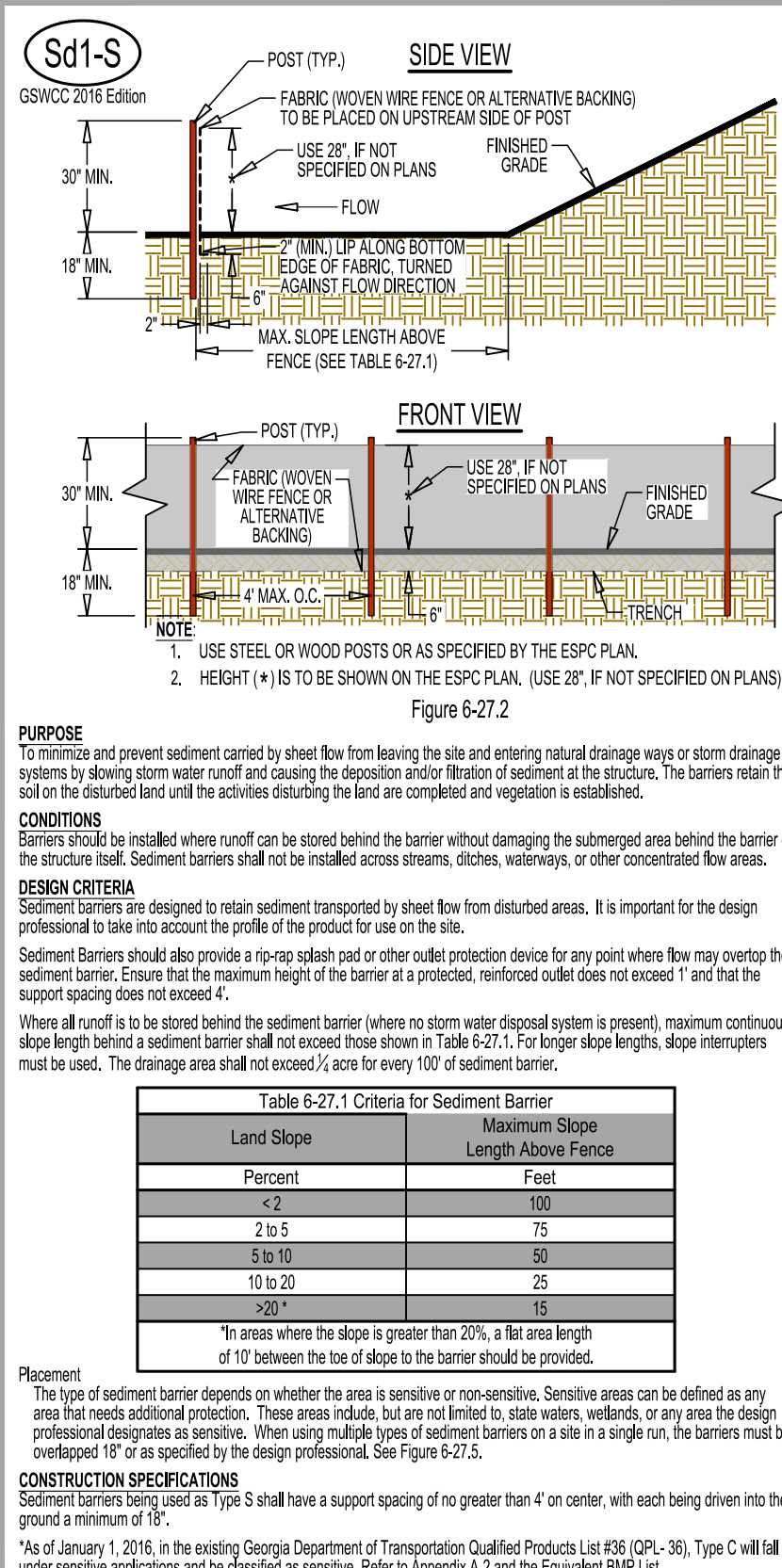

Figure 6-27.2

PURPOSE
To minimize and prevent sediment carried by sheet flow from leaving the site and entering natural drainage ways or storm drainage systems by slowing storm water runoff and causing the deposition and/or filtration of sediment at the structure. The barriers retain the soil on the disturbed land until the activities disturbing the land are completed and vegetation is established.

CONDITIONS
Barriers should be installed where runoff can be stored behind the barrier without damaging the submerged area behind the barrier or the structure itself. Sediment barriers shall not be installed across streams, ditches, waterways, or other concentrated flow areas.

DESIGN CRITERIA
Sediment barriers are designed to retain sediment transported by sheet flow from disturbed areas. It is important for the design professional to take into account the profile of the product for use on the site. Sediment Barriers should also provide a rip-rap apron and/or other outlet protection device for any point where flow may occur over the sediment barrier. Ensure that the maximum height of the barrier at a protected, reinforced outlet does not exceed 1' and that the support spacing does not exceed 4'.

INSTALLATION
Where all runoff is to be stored behind the sediment barrier (where no storm water disposal system is present), maximum continuous slope length behind a sediment barrier shall not exceed those shown in Table 6-27.1. For longer slope lengths, slope interrupters must be used. The drainage area shall not exceed 1/2 acre for every 100' of sediment barrier.

SENSITIVE AREA(S) SEDIMENT BARRIER (TYPE C SILT FENCE) - (Sd1-S)
N.T.S.

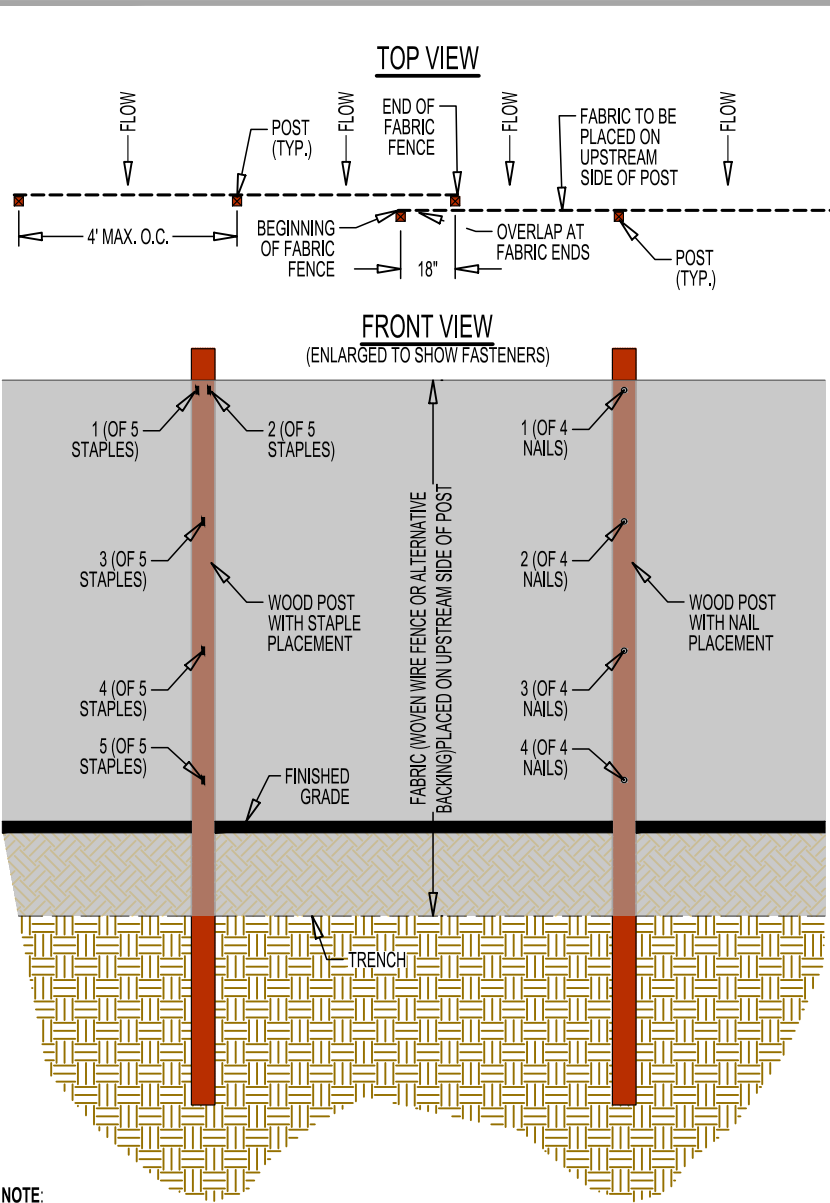

Figure 6-34.3 - Rip-rap Outlet Protection

Table 6-27.1 Criteria for Sediment Barrier

Land Slope	Maximum Slope	Length of Fabric
Percent	Feet	
<2	100	
2 to 5	75	
5 to 8	50	
10 to 20	25	
>20*	15	

*In areas where the slope is greater than 20%, a flat area length of 10' between the top of slope to the barrier shall be provided.

Table 6-27.2 Post Size

Type	Min. Length	Type of Post	Size of Post
S	4'	Steel	1.15-1.25 lb./ft. min. Oak

Table 6-27.3 Fasteners for Wood Posts

Type	Gauge	Crown	Legs	Staples per Post
Wire Staples	17 min.	3/4" wide	7/8" long	5 min.
Nails	14 min.	1"	3/4"	4 min.

Table 6-27.4 Type C Fabric Fence

Tensile Strength (Lbs. Min.) ¹ (ASTM D-4632)	Warp - 260 Fill - 180
Elongation (% Max.) (ASTM D-4632)	40
AOS (Apparent Opening Size) (Max. Sieve Size) (ASTM D-4751)	#30
Flow Rate (Gal/Min/Sq. Ft.) (GD7-87)	70
Ultraviolet Stability ² (ASTM D-4632 after 300 hours weathering in accordance with ASTM D-4355)	80
Burning Strength (PSP Min.) (ASTM D-3786 DuPont/Burn) Burning Strength (Tester)	175
Minimum Fabric Width (Inches)	36

¹ Minimum roll weight of the specimens.
² Percent of required initial minimum tensile strength.

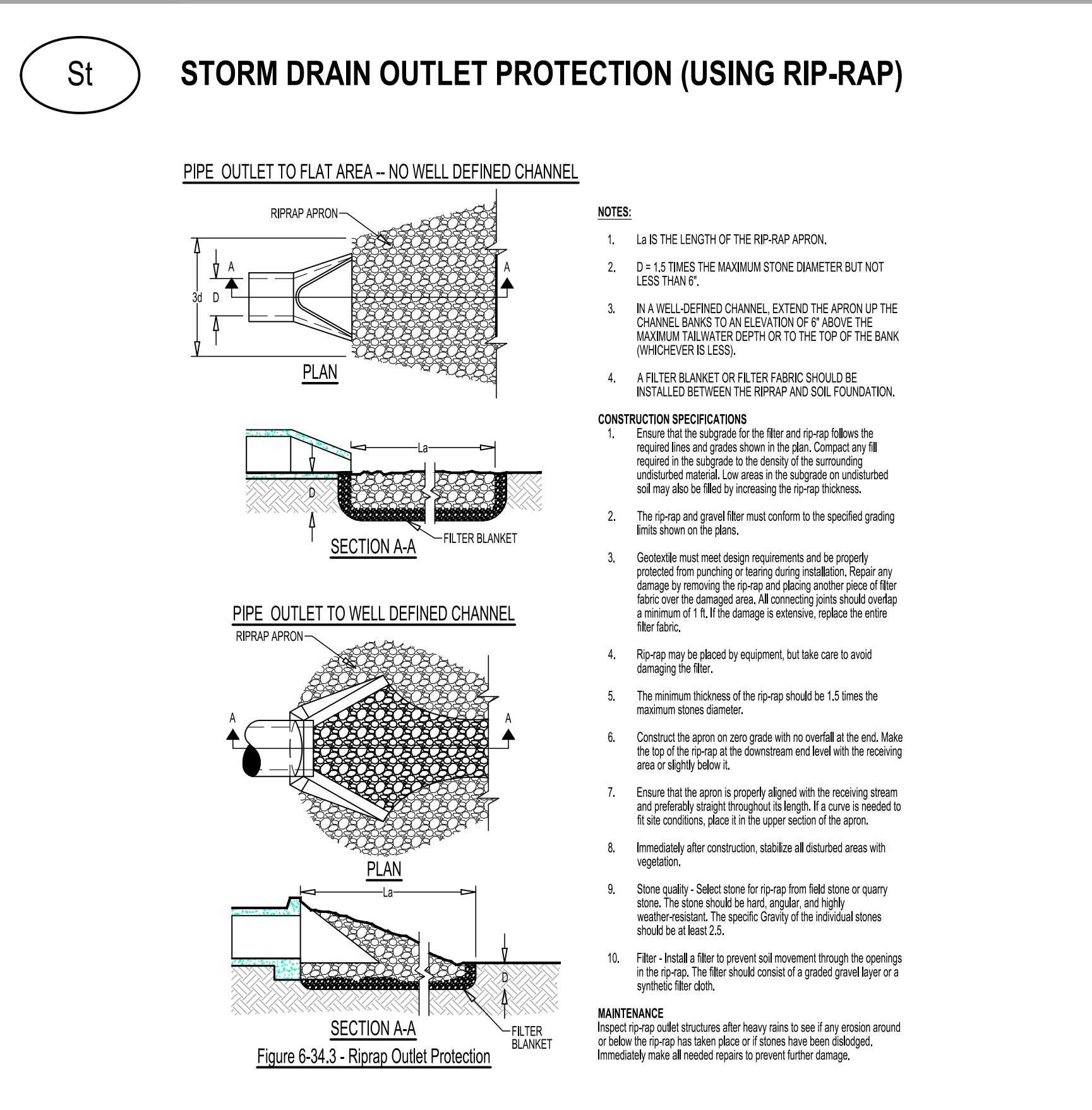

Figure 6-34.3 - Rip-rap Outlet Protection

Table 6-34.3 - Rip-rap Outlet Protection

Type	Min. Length	Type of Post	Size of Post
S	4'	Steel	1.15-1.25 lb./ft. min. Oak

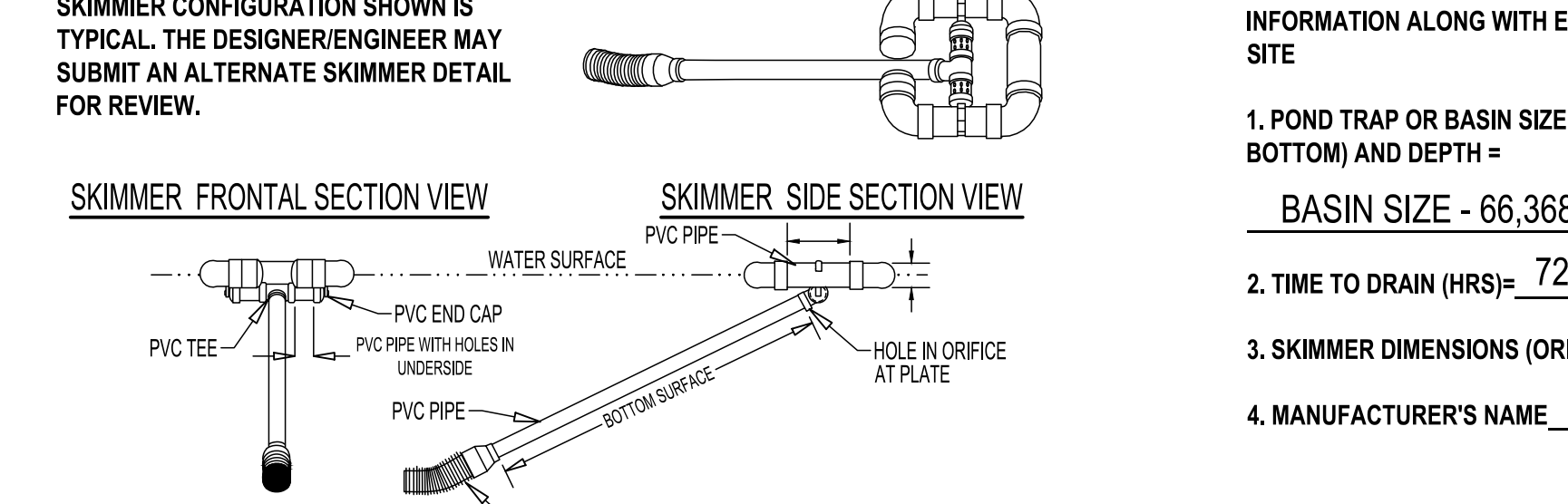

Figure 6-31.4

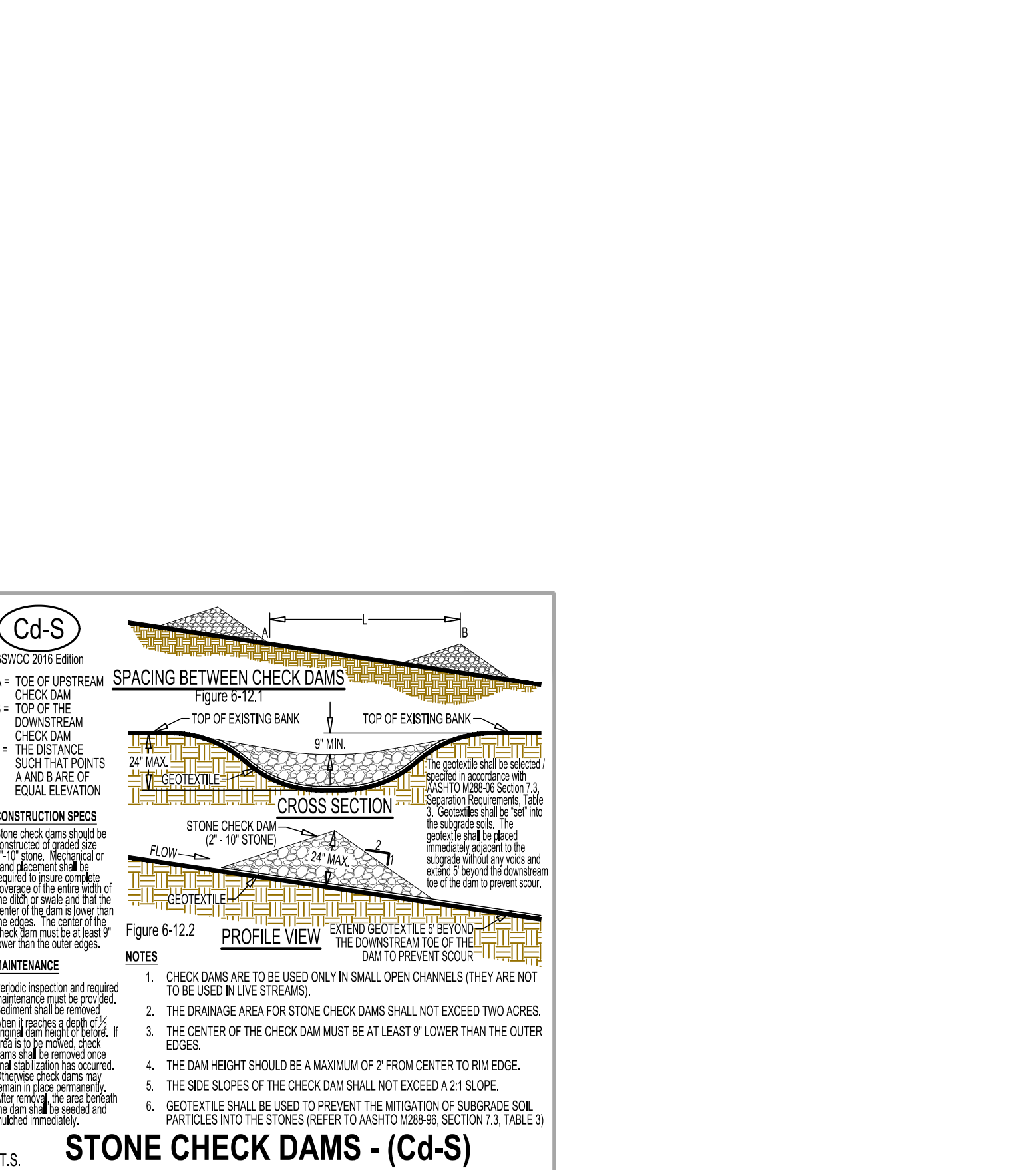

Figure 6-12.2

Table 6-12.2 Spacing Between Check Dams

Land Slope	Maximum Slope	Length of Fabric
Percent	Feet	
<2	100	
2 to 5	75	
5 to 8	50	
10 to 20	25	
>20*	15	

*In areas where the slope is greater than 20%, a flat area length of 10' between the top of slope to the barrier shall be provided.

STONE CHECK DAMS - (Cd-S)
N.T.S.

St
STORM DRAIN OUTLET PROTECTION (USING RIP-RAP)

PIPE OUTLET TO FLAT AREA - NO WELL DEFINED CHANNEL

PIPE OUTLET TO WELL DEFINED CHANNEL

CONSTRUCTION SPECIFICATIONS

1. Ensure that the subgrade for the filter and rip-rap follows the required lines and grades shown in the plan. Compact any fill required in the subgrade to the density of the surrounding undisturbed material. Low areas in the subgrade on undisturbed soil may be filled by increasing the rip-rap thickness.
2. The rip-rap and gravel filter must conform to the specified grading limits shown on the plans.
3. Geotextile must meet design requirements and be properly protected from punching or tearing during installation. Repair any damage by removing the rip-rap and placing another piece of filter fabric over the damaged area. All connecting joints should overlap a minimum of 18\"/>

CONSTRUCTION SPECIFICATIONS

1. Ensure that the subgrade for the filter and rip-rap follows the required lines and grades shown in the plan. Compact any fill required in the subgrade to the density of the surrounding undisturbed material. Low areas in the subgrade on undisturbed soil may be filled by increasing the rip-rap thickness.
2. The rip-rap and gravel filter must conform to the specified grading limits shown on the plans.
3. Geotextile must meet design requirements and be properly protected from punching or tearing during installation. Repair any damage by removing the rip-rap and placing another piece of filter fabric over the damaged area. All connecting joints should overlap a minimum of 18\"/>

STONE CHECK DAMS - (Cd-S)
N.T.S.

Sk
SKIMMER PERSPECTIVE

SKIMMER FRONTAL SECTION VIEW

SKIMMER SIDE SECTION VIEW

NOTE:
SKIMMER CONFIGURATION SHOWN IS TYPICAL. THE DESIGNER/ENGINEER MAY SUBMIT AN ALTERNATE SKIMMER DETAIL FOR REVIEW.

TO BE SHOWN ON THE EROSION, SEDIMENTATION AND POLLUTION CONTROL PLAN WHEN A FLOATING SURFACE SKIMMER IS USED, SHOW THE FOLLOWING INFORMATION ALONG WITH EACH SEDIMENT POND, TRAP OR BASIN BEING USED ON SITE

1. POND TRAP OR BASIN SIZE, LENGTH* (TOP AND BOTTOM), WIDTH* (TOP AND BOTTOM) AND DEPTH =

BASIN SIZE - 66,368 CUBIC FEET

2. TIME TO DRAIN (HRS) = 72 HOURS

3. SKIMMER DIMENSIONS (ORIFICE AND HEAD SIZE)** 75% ORIFICE PERCENTAGE

4. MANUFACTURER'S NAME FAIRCLOTH SKIMMERS

*FEET,** INCHES

INLET SEDIMENT TRAP (FILTER FABRIC W/ SUPPORTING FRAME) - (Sd2-F)
N.T.S.

SENSITIVE AREA(S) SEDIMENT BARRIER (TYPE C SILT FENCE) - (Sd1-S)
N.T.S.

STONE CHECK DAMS - (Cd-S)
N.T.S.

DRYWALL WAREHOUSE HWY 81
257 HIGHWAY 81
OXFORD, GA 30054
ZONING: R-1

georgia civil
CIVIL ENGINEERING
LANDSCAPE ARCHITECTURE
LAND SURVEYING
311 N. Main St., Ste. 101, Unit C
P.O. Box 896 | Madison, GA 30650
P: 706.342.1104
www.georgiacivil.com

Professional Seal
REGISTERED PROFESSIONAL ENGINEER
JASON P. BROWN

Project Information

DRAWING DATE: 5/27/2026
DRAWN BY: DLD
CHECKED BY: JPB

REVISIONS
DATE: DESCRIPTION:

© Copyright 2026 georgia civil, inc.
This document and its reproduction are the property of Georgia Civil, Inc. and may not be reproduced, published, or used in whole or in part without the written consent of Georgia Civil, Inc.

Sheet Title

EROSION
SEDIMENTATION AND
POLLUTION CONTROL
DETAILS

Sheet Number
C-6.7