

1 DIFFUSER RUN OUT DETAIL
M0.4 NOT TO SCALE

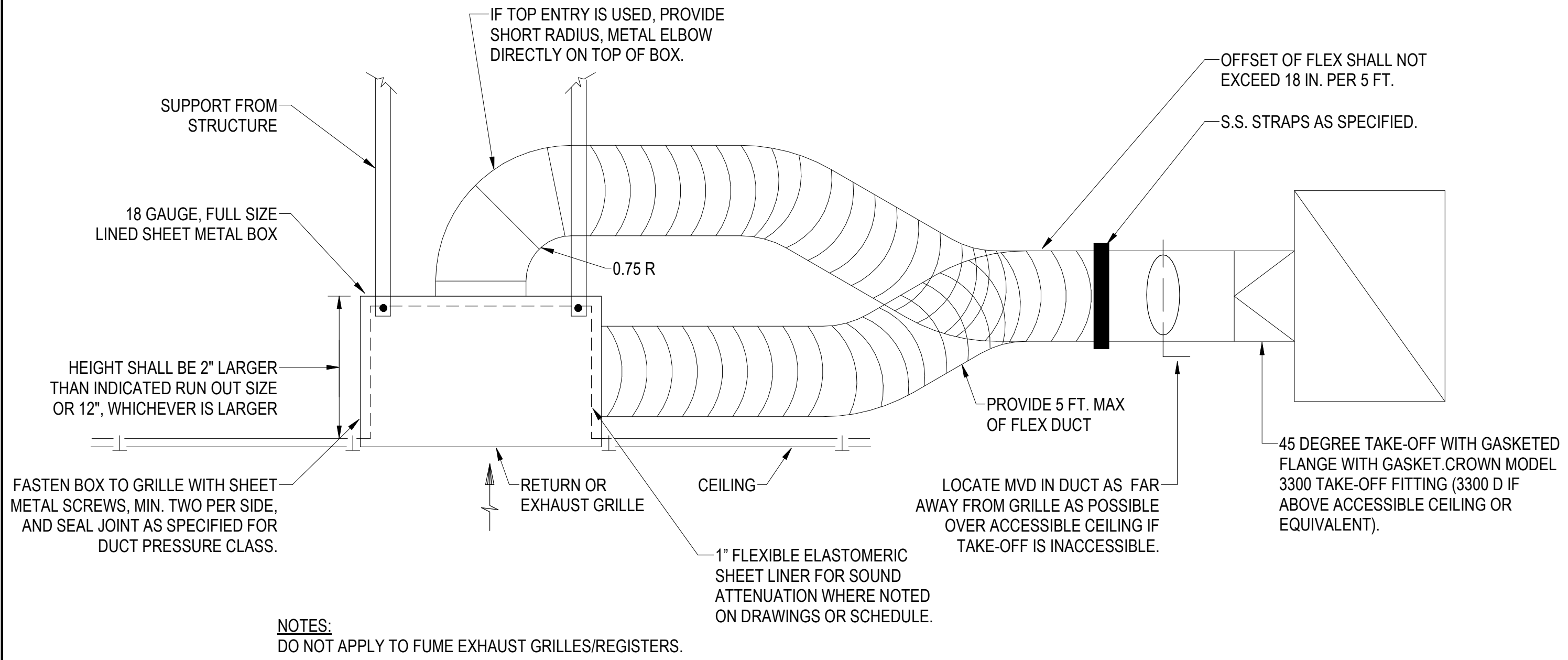

2 DETAIL AT TYPICAL GENERAL RETURN AND EXHAUST GRILLE - LINED
M0.4 NOT TO SCALE

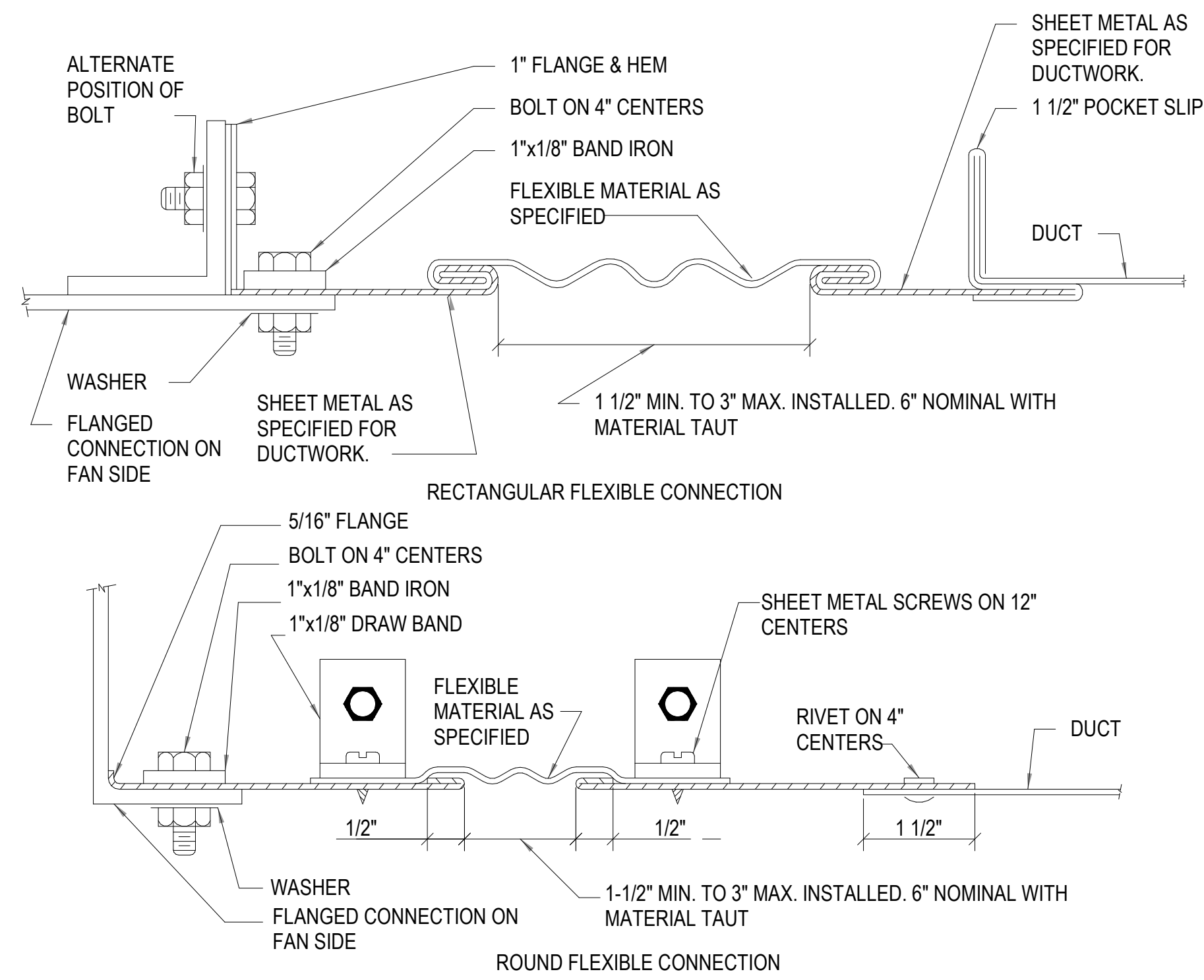

3 EQUIPMENT FLEXIBLE CONNECTION RECTANGULAR/ROUND
M0.4 NOT TO SCALE

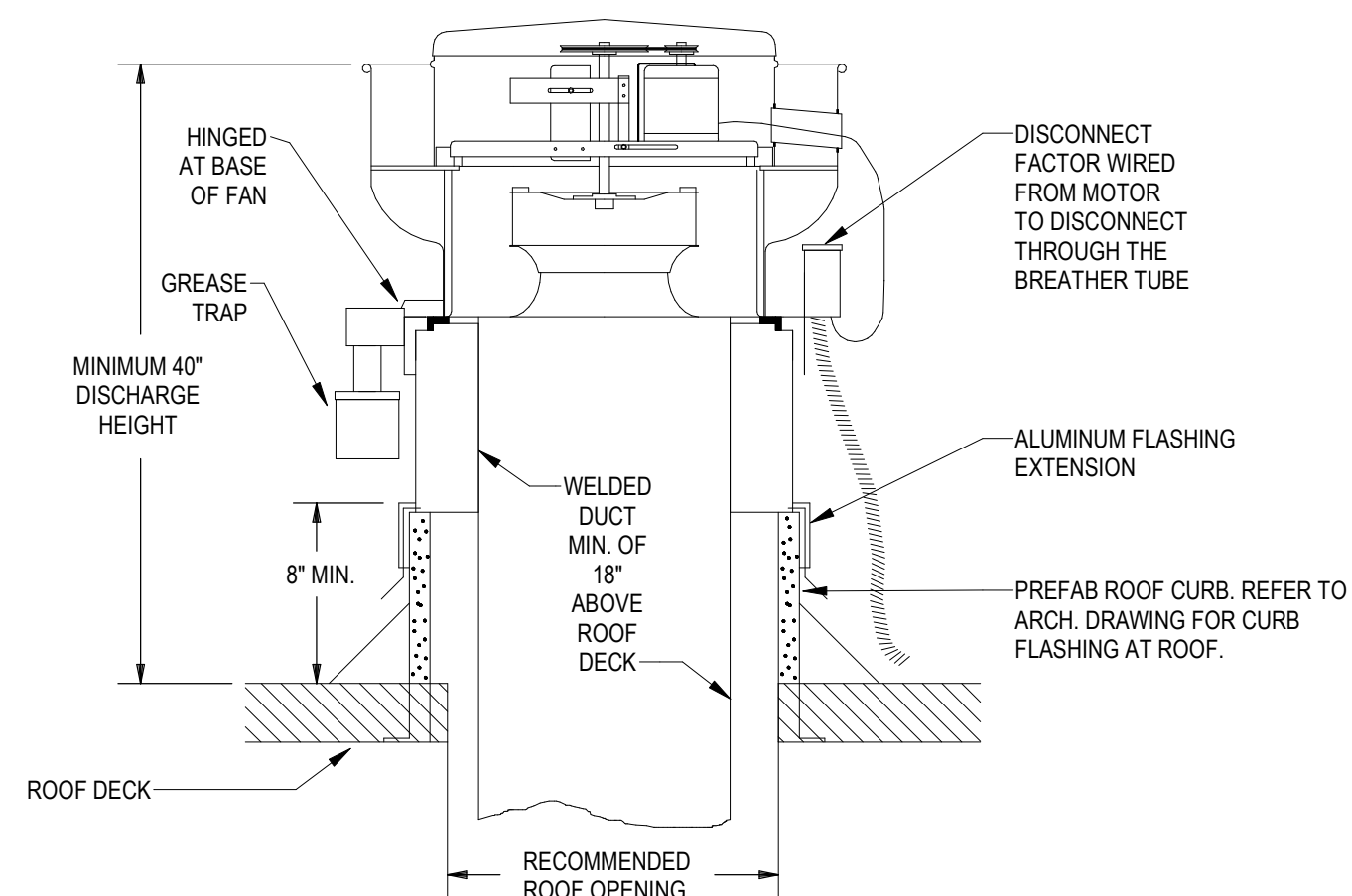

4 KITCHEN EXHAUST FAN DETAIL
M0.4 NO SCALE

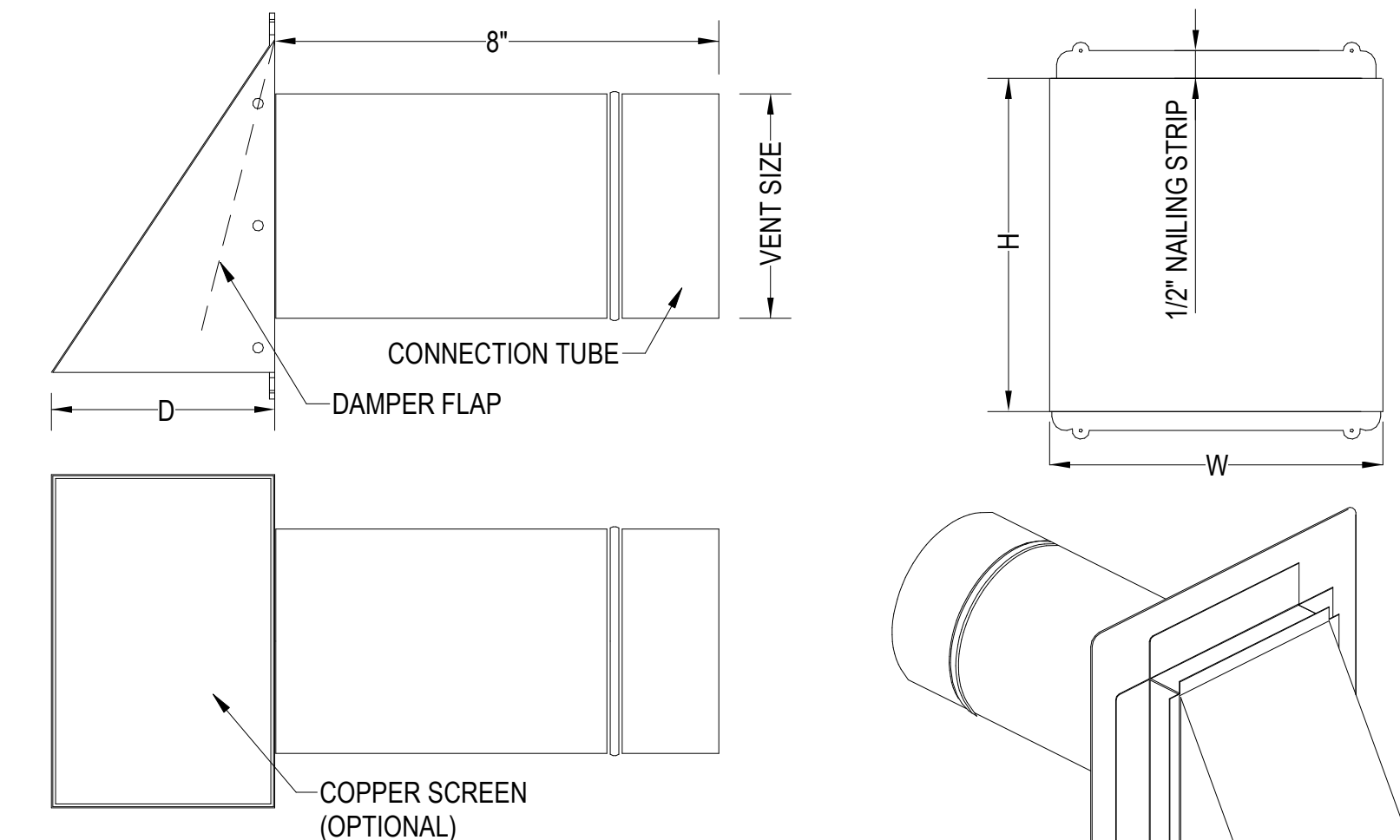

MATERIAL 22 GAUGE STAINLESS STEEL

VENT SIZE	W x H x D	FREE AREA
4"	6"x6"x4"	24 in ²
6"	9 1/4"x9 1/4"x6 1/4"	57 in ²
8"	10 1/4"x10 1/4"x7"	71 in ²
10"	11 1/2"x11 1/2"x7 3/4"	88 in ²
12"	14"x14"x9 1/4"	128 in ²

BASIS OF DESIGN:
THUNDERBIRD PRODUCTS
1148 NORTH MARSHALL AVE.
EL CAJON, CA 92020
TEL: (800) 658-2473
FAX: (619) 448-9072

5 VENT CAP AT EXTERIOR WALL DETAIL
M0.4 NOT TO SCALE