

AND LOCAL CODES & REGULATIONS.
ADA PARKING SIGN DETAIL
 N.T.S.

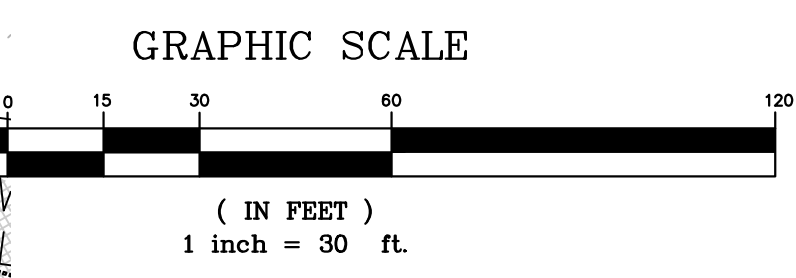

CAUTION

CONTRACTOR SHALL BE RESPONSIBLE FOR SECURING THE SERVICES OF A PRIVATE UTILITY LOCATOR FIRM DURING THE ENTIRE COURSE OF CONSTRUCTION. CONTRACTOR SHALL PAY FOR SAID SERVICES. CONTRACTOR SHALL REPAIR ALL UTILITIES DAMAGED BY CONSTRUCTION ACTIVITIES, AT NO ADDITIONAL COST TO THE OWNER/DEVELOPER.

THE UTILITIES SHOWN ARE SHOWN FOR THE CONTRACTOR'S CONVENIENCE ONLY. THERE MAY BE OTHER UTILITIES NOT SHOWN ON THESE PLANS. THE SITE DESIGN PROFESSIONAL ASSUMES NO RESPONSIBILITY FOR THE LOCATIONS SHOWN AND IT SHALL BE THE CONTRACTOR'S RESPONSIBILITY TO VERIFY THE LOCATIONS OF UTILITIES WITHIN THE LIMITS OF THE WORK. DAMAGE TO EXISTING UTILITIES BY THE CONTRACTOR, FROM HIS/HER OPERATIONS SHALL BE THE SOLE RESPONSIBILITY OF THE CONTRACTOR.

CONTRACTOR SHALL BE RESPONSIBLE FOR COMPACTION OF BACKFILL OF ALL UTILITY TRENCHES WITHIN SITE WORK LIMITS. THIS INCLUDES TRENCHES DUG AND BACKFILLED BY LOCAL UTILITIES, SUCH AS POWER, GAS, TELEPHONE, ETC. CONTRACTOR SHALL PROVIDE ADDITIONAL BACKFILL AND COMPACTION AS NECESSARY, IF SETTLEMENT OCCURS.

DO NOT DUPLICATE DRAWINGS WITHOUT PERMISSION

PARKING SPACES

PER PARKING REGULATIONS FROM HENRY COUNTY, THE REQUIRED NUMBER OF PARKING SPACES FOR THIS C-STORE IS:

- CONVENIENCE STORE**
4000SF X (1 SPACE / 150 SF) = 27 SPACES
 - GAS STATION**
8 PUMPS X (1 SPACE / 2 PUMPS) = 4 SPACES
 - RETAIL/RESTAURANT**
1500SF X (1 SPACE / 150 SF) = 10 SPACES
8 EMPLOYEES X (1 SPACE / EMPLOYEE) = 8 SPACES
 - FUTURE BUILDING**
6250SF X (1 SPACE / 150SF) = 42 SPACES
 - TOTAL REQUIRED**
91 SPACES
- THERE ARE 91 PARKING SPACES PROVIDED INCLUDING 4 ADA SPACES.

NOTE:

DECEL LANE AND ACCEL TAPER PAVING WITHIN HCDOT ROW FOR INDUSTRIAL : DECEL LANE HAS A MINIMUM PAVING SECTION OF 10' GAB, 4" BASE (1 LIFT OF 25MM SO OR 2 LIFTS OF BINDER (19 MM SP)), AND 1.5" OF TOPPING (12.5 MM SP OR 9.5MM SP, TP 2)

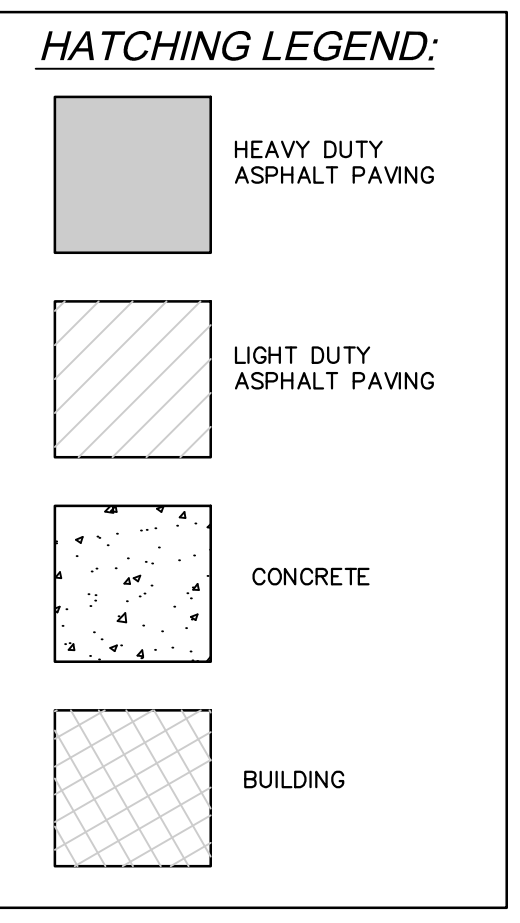

SIGHT DISTANCE CERTIFICATION

ALL PROPOSED DRIVES MEET AASHTO SIGHT DISTANCE REQUIREMENTS.
 FOR 45 MPH, ISD LOOKING LEFT >= 500'
 FOR 45 MPH, ISD LOOKING RIGHT >= 500'

SIGNED *Robert Eugene Moore Jr*
 DATE 05/11/23

GEORGIA811
 www.Georgia811.com

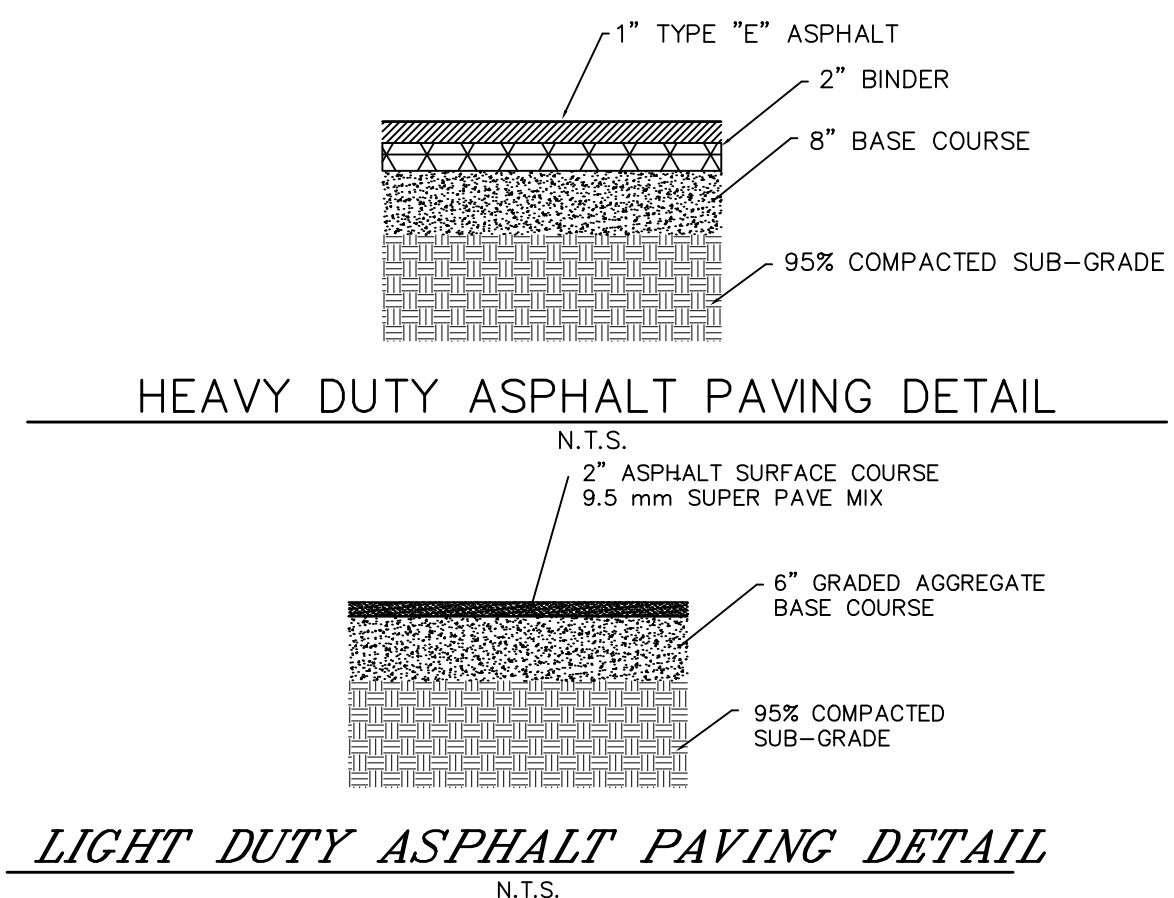
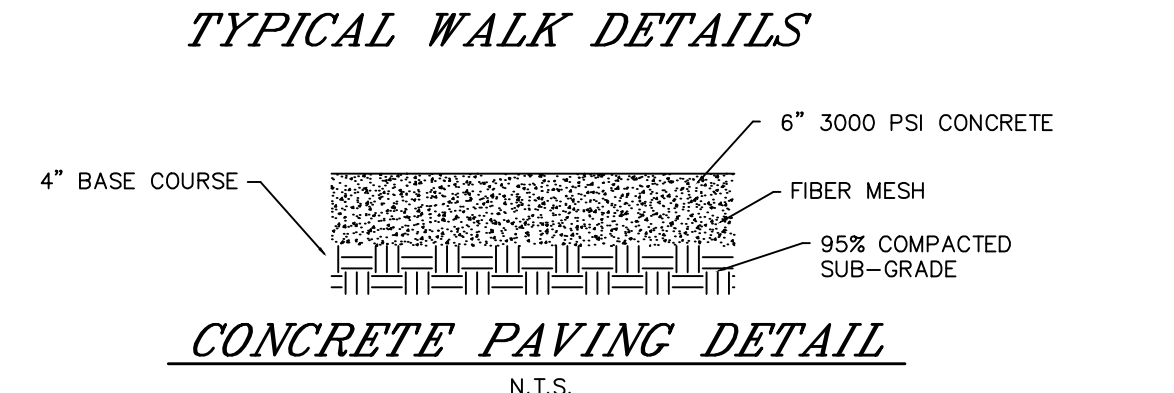
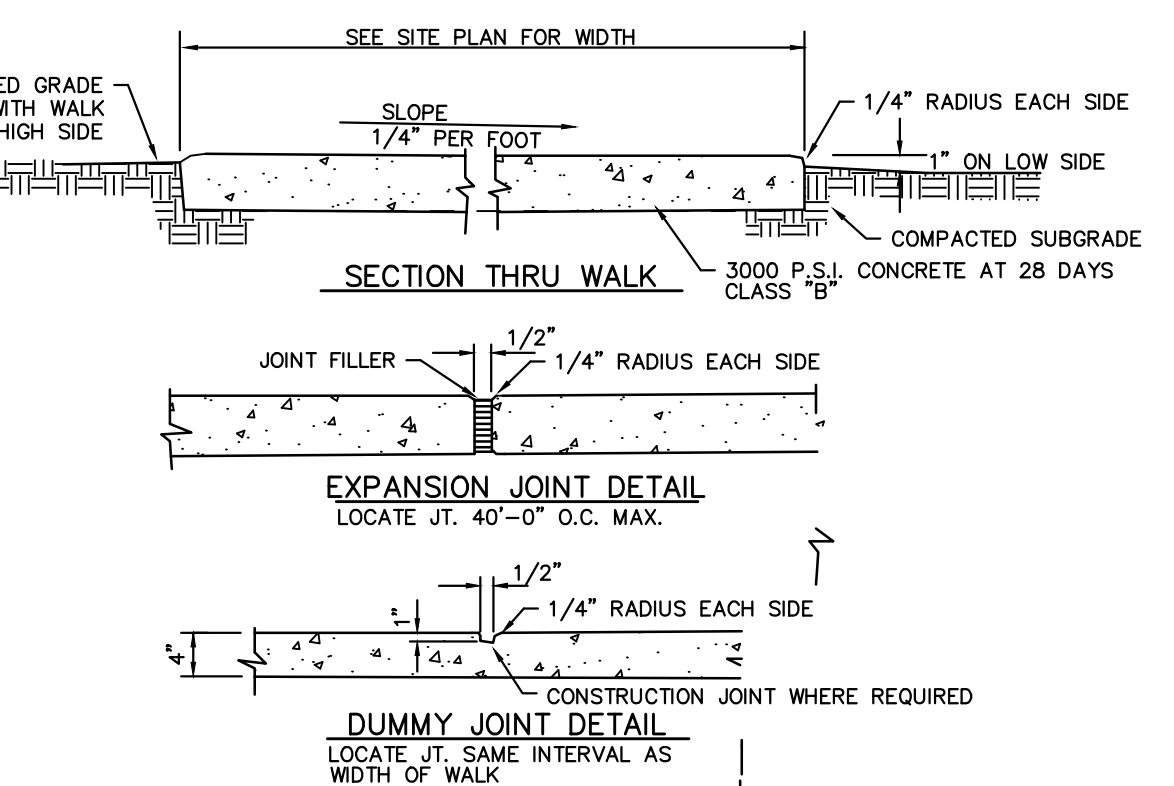
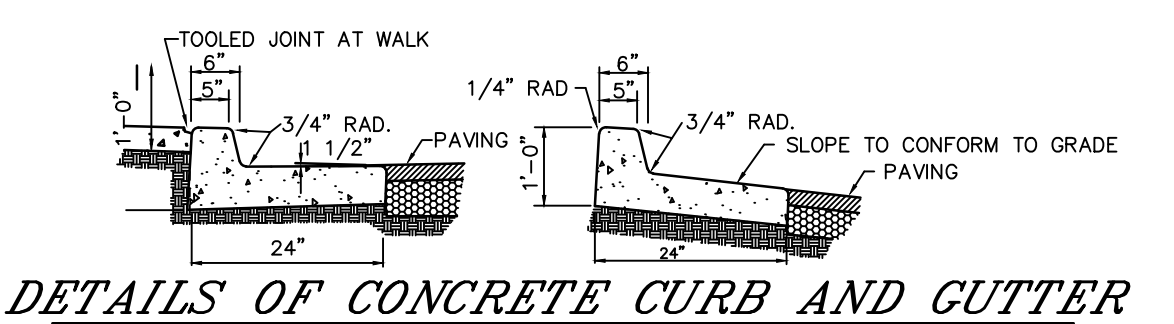

MOORE CIVIL
 CONSULTING-DESIGN-ENGINEER
 ROBERT@MOORECIVIL.COM
 706.224.1629

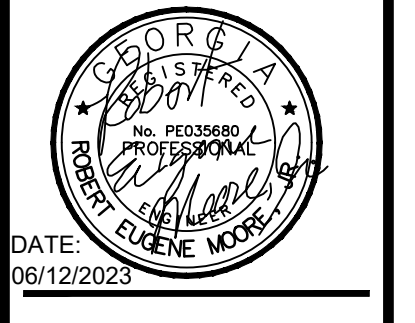

DATE: 06/12/2023

This document, together with the concepts and designs presented herein, as an instrument of services, is intended only for the specific purpose and client for which it was prepared. Reuse of and improper reliance on this document without written authorization by Moore Civil Consulting, Inc. shall be without liability to Moore Civil Consulting, Inc. Copyright Moore Civil Consulting, Inc. 2018

24 HOUR CONTACT
 MEHULKUMAR GAJJAR
 404-483-2157

CLIENT:
 HANSA PATEL
 908 DONAGAL DR
 LOCUST GROVE, GA, 30248
 404-483-2157

OWNER INFORMATION:
 HANSA PATEL
 908 DONAGAL DR
 LOCUST GROVE, GA, 30248
 404-483-2157

REVISIONS:

02/12/22	GRADING PLAN
10/21/22	1st LDP SUBMITTAL
10/21/22	1ST GDOT SUBMITTAL
01/30/2023	NEW LAYOUT
02/21/2023	NEW LAYOUT
05/09/2023	2nd LDP SUBMITTAL
05/09/2023	2nd GDOT SUBMITTAL
12/19/2023	3rd GDOT SUBMITTAL
12/19/2023	3rd LDP SUBMITTAL
03/05/2023	4rd LDP SUBMITTAL
03/05/2023	3rd GDOT SUBMITTAL
04/24/2024	6TH GDOT SUBMITTAL
05/21/2024	7TH GDOT SUBMITTAL
12/12/2024	8TH GDOT SUBMITTAL
03/06/2025	5TH LDP SUBMITTAL
07/03/2025	6TH LDP SUBMITTAL

HWY 81 C-STORE
 HWY 81
 HAMPTON, GA 30228

SHEET TITLE:
SITE PLAN

SHEET NUMBER:
C.200