

1 ELECTRIC WATER HEATER DETAIL
SCALE: NONE

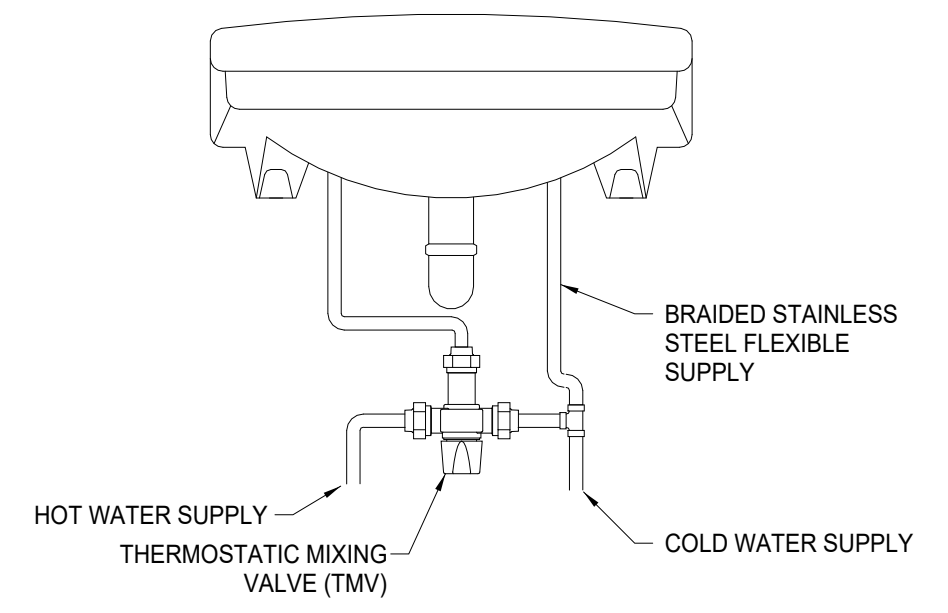

2 THERMOSTATIC MIXING VALVE AT HAND SINK DETAIL
SCALE: NONE

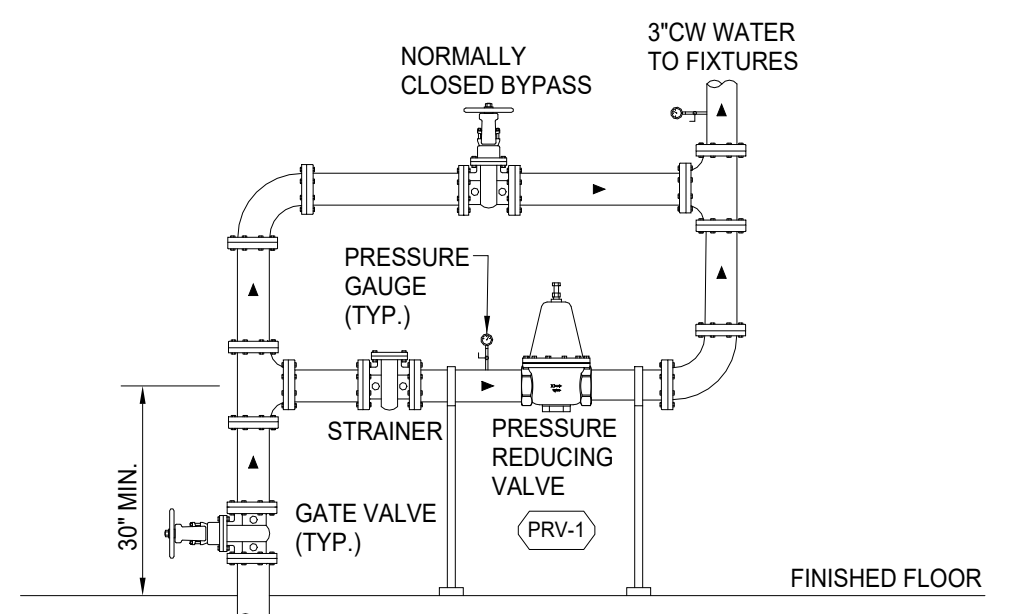

3 BUILDING WATER SERVICE DETAIL
SCALE: NONE

FIXTURE NO.	DESCRIPTION	MANUFACTURER & MODEL	PIPING CONNECTIONS				ACCESSORIES	REMARKS
			S/W	VENT	CW	HW		
FCO-1	FLOOR CLEAN OUT W/ HEAVY DUTY ADJUSTABLE ROUND TOP, EPOXY COATED CAST IRON	WATTS CO-260	VARIES	-	-	-	-	SAME SIZE AS PIPE MAXIMUM 4"
FD-1	FLOOR DRAIN, 6" NICKEL BRONZE ADJUSTABLE STRAINER	WATTS FD-300-5	3"	-	-	-	PROVIDE TRAP GUARD	-
FD-2	FLOOR DRAIN, 6" NICKEL BRONZE ADJUSTABLE STRAINER	WATTS FD-100-A	4"	-	-	-	PROVIDE TRAP GUARD	-
LAV-1	WALL MOUNTED LAVATORY, VITREOUS CHINA, REFER TO ARCHITECTURAL PLANS FOR MOUNTING HEIGHTS	KOHLER K-2032	2"	1 1/2"	1/2"	1/2"	FAUCET (0.5GPM), 4" TRIM PLATE, TMV, SS STRAINER, SUPPLIES, STOPS, TRAP, AND ESCUTCHEON PLATE, CARRIER	ELECTRONIC FAUCET, SLOAN EAF-100-PLG-CP-0.35GPM-MLM-IR-IG-FCT-PLUG-IN, 120V/6VDC ADAPTER, THERMOSTATIC MIXING VALVE WATTS MODEL LFMMV, 0.5GPM AERATOR, 105°F OUTLET TEMPERATURE
PRV-1	DIRECT ACTING PRESSURE REDUCING VALVE WITH STRAINER	WATTS LFN223BS	3"	-	-	-	-	ADJUST TO 25PSI REDUCED PRESSURE RANGE
SK-1	STAINLESS STEEL, DOUBLE COMPARTMENT SINK, UNDERMOUNT, TWO 16"X16"X10" DEEP BOWLS	ELKAY ELUH581710DBG	2"	1 1/2"	1/2"	1/2"	FAUCET, SS STRAINERS, SUPPLIES, STOPS, TRAP, TAILPIECE, AND ESCUTCHEON PLATES	FAUCET: ELKAY LKGT1041 SINGLE HOLE FAUCET W/ PULLOUT SPRAY, CHROME FINISH
UR-1	URINAL, WALL MOUNTED, VITREOUS CHINA, 0.125GPF, REFER TO ARCHITECTURAL PLANS FOR MOUNTING HEIGHTS	KOHLER BARDON K-4904-ET	2"	1 1/2"	3/4"	-	HARD WIRED SENSOR FLUSH VALVE W/ OVERRIDE BUTTON, CARRIER	SENSOR HARD WIRED FLUSH VALVE, SLOAN SLOAN 186 ESS-0.125-DBP-TMO-HW, SLOAN TRANSFORMER 0345154
WC-1	WATER CLOSET, FLUSH VALVE, WALL MOUNTED, VITREOUS CHINA, 1.0 GPF, REFER TO ARCHITECTURAL PLANS FOR MOUNTING HEIGHTS	KOHLER KINGSTON K-4325	4"	2"	1"	-	SENSOR FLUSH VALVE, OPEN FRONT SEAT, CARRIER	SENSOR HARD WIRED FLUSH VALVE, SLOAN 111 ESS-1.28-DFB-OR-HW, SLOAN TRANSFORMER 0345154
WH-1	WALL HYDRANT, ENCASED NON-FREEZE, SATIN NICKEL BOX, HINGED WITH LOCKING COVER, VACUUM BREAKER (ASSE 1052)	PRIER C-634BX1	-	-	3/4"	-	-	ORDER LENGTH AS REQUIRED BASED ON WALL THICKNESS

ELECTRIC WATER HEATER SCHEDULE (EWH)									
PLAN DESIGNATION	MANUFACTURER MODEL NO.	TYPE	LOCATION	STORAGE CAPACITY (GAL)	GALLONS/HR @100° F RISE	ELECTRICAL DATA			NOTES
						KW/AMPS	VOLTS/ PHASE	HERTZ	
EWH-1	A O SMITH ENL-30	ELECTRIC TANK	SECOND FLOOR MECH ROOM	30	41	6	208/1Ø	60	1

NOTES:
 1. PROVIDE THE FOLLOWING STANDARD AND OPTIONAL EQUIPMENT:
 - ASME CONSTRUCTION
 - ASME PRESSURE/TEMPERATURE RELIEF VALVE TEMPERATURE CONTROL
 - JUNCTION BOX WITH TERMINAL BLOCK

HOT WATER RETURN PUMP SCHEDULE (HWRP)												
PLAN DESIGNATION	MANUFACTURER MODEL NO.	SERVICE	LOCATION	TOTAL HEAD (FT)	FLOW (GPM)	POWER (HP)	RPM	ELECTRICAL DATA				NOTES
								VOLTS	PHASE	HERTZ	F.L.A.MPS	
HWRP-1	BELL & GOSSETT NBF-8SILW	DOMESTIC WATER	PROCESS BUILDING MECH ROOM	6	2	1/16	2800	115	1	60	0.80	1,2,3

NOTES:
 1. BRONZE BODY CONSTRUCTION, NON FERROUS IMPELLER
 2. PROVIDE AQUASTAT AND AUTOMATIC TIMER KIT.
 3. PROVIDE ELECTRICAL DISCONNECT.
 4. NSF COMPLIANT



THIS DRAWING IS NOT VALID FOR CONSTRUCTION PURPOSES UNLESS IT BEARS THE SEAL AND SIGNATURE OF A DULY REGISTERED PROFESSIONAL

60% DESIGN



NCWSA OFFICE ADDITION

REVISIONS

REV	DATE	DESCRIPTION

LINE IS 2 INCHES AT FULL SIZE

DESIGNED: TIP
 DRAWN: TIP
 CHECKED: RFJ
 CHECKED:
 APPROVED:

FILENAME
 BC PROJECT NUMBER 616202
 CLIENT PROJECT NUMBER

SCHEDULES AND DETAILS

DRAWING NUMBER
P301

Plot Date: 3/23/2026 1:31:45 PM Path: Autodeskt Docs\NCWSA Admin Bldg_V251616202-NCWSA-PLG_V25.rvt