

FRAME TYPES

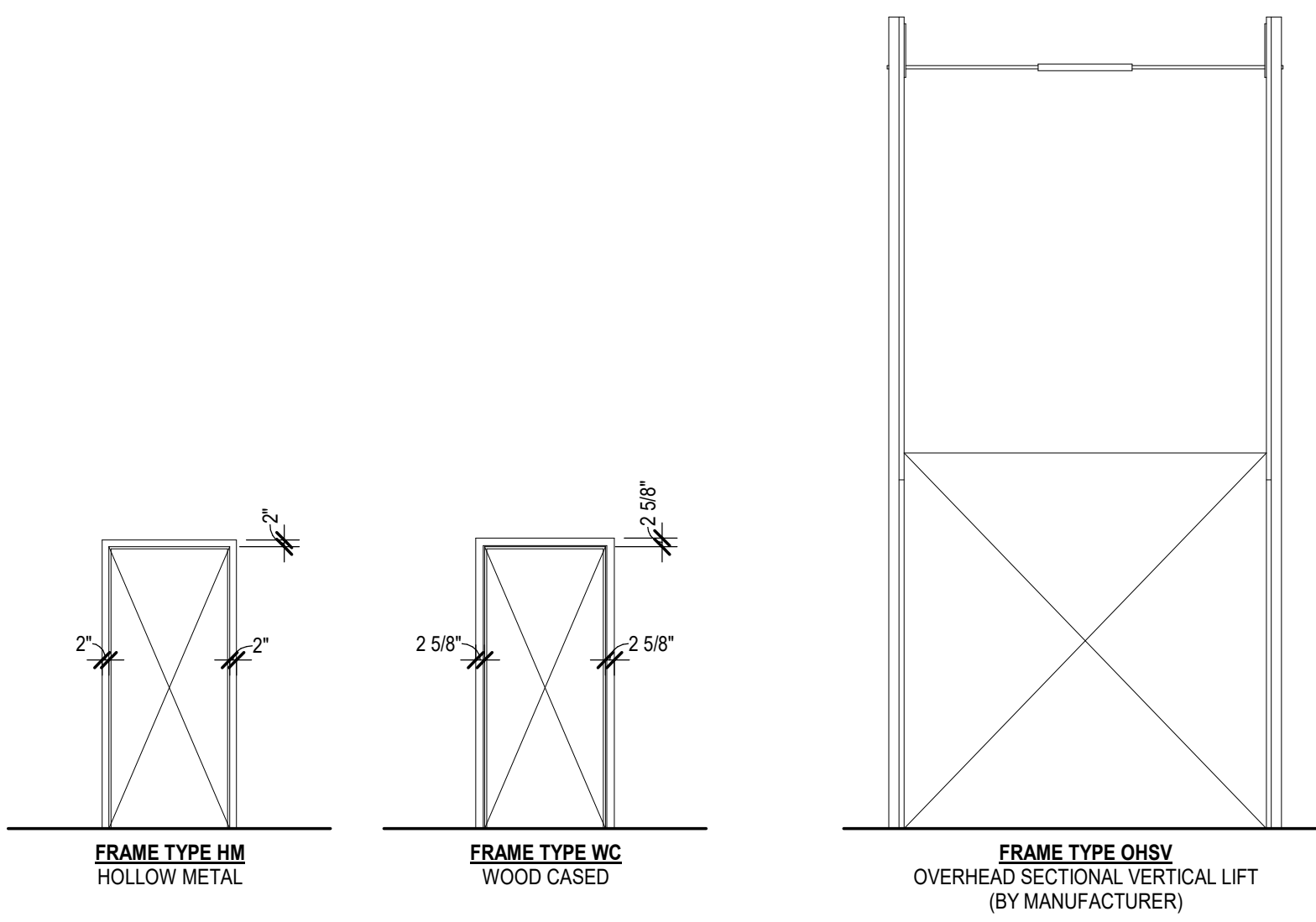

DOOR TYPES

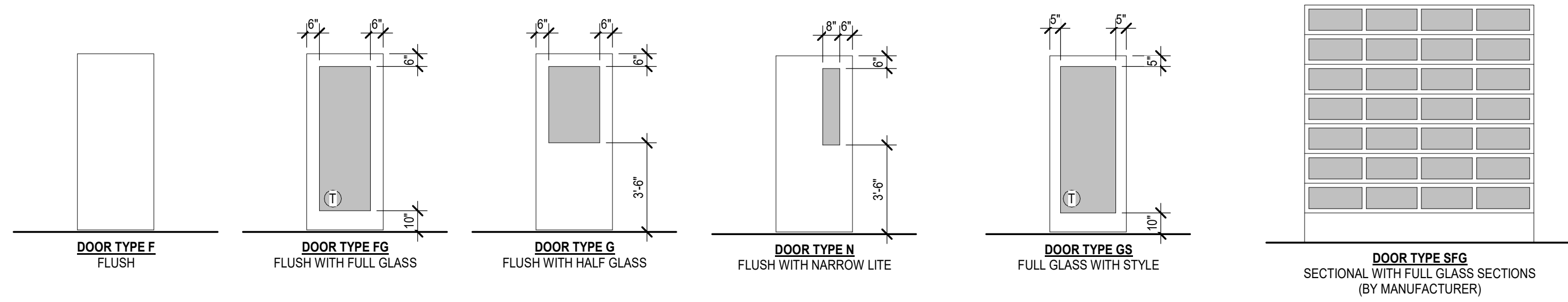

DOOR AND FRAME GENERAL NOTES

- UNDERCUT THE BOTTOMS OF DOORS TO CLEAR THE TOP OF FINISHED FLOOR, BY 1/2" MAXIMUM. U.N.O. VERIFY SLAB CONDITIONS AND TRIM EACH DOOR TO FIT CONDITION. WHERE RADICAL VARIATIONS IN FLOOR LEVEL EXIST, DOORS SHALL BE ORDERED WITH BOTTOM STILE SIZED TO ACCOMMODATE THESE UNDERCUT CONDITIONS.
- ROUGH OPENING FOR DOOR, CONFIRM WITH MANUFACTURER FOR SHIMMING REQUIREMENTS.
- CAULK THE JOINT BETWEEN THE FRAME AND WALL, ALL SIDES, WITH PAINTABLE WHITE LATEX CAULK.
- CONTRACTOR SHALL REVIEW KEYING WITH OWNER PRIOR TO FITTING CYLINDERS. KEY CYLINDERS TO OWNER'S MASTER.
- DOOR PANELS SHOWN FOR COORDINATION PURPOSES ONLY. COORDINATE FINAL PANEL DESIGN WITH INTERIOR DESIGN SCOPE.
- LETTER 'T' ON GLAZING INDICATES LOCATION OF SAFETY GLAZING. SEE SCHEDULE FOR LOCATION. SAFETY GLASS TO COMPLY WITH IBC SECTION 2406.
- ALL GLAZING IN EXTERIOR DOORS TO MATCH EXTERIOR WINDOW GLAZING.
- ALL EXTERIOR DOORS SHALL BE INSULATED.
- COORDINATE WITH MECHANICAL REQUIREMENTS FOR REQUIRED UNDERCUT IF ANY.
- ALL INTERIOR SOLID WOOD DOOR FINISH TO BE NATURAL BIRCH TO BE FILED OR FACTORY STAINED COLOR SELECTED BY OWNER.
- GLASS & GLAZING, HOLLOW METAL, ALUMINUM FRAME, AND HARDWARE SUPPLIERS SHALL BE RESPONSIBLE FOR CODE COMPLIANCE FOR ALL MATERIAL FURNISHED.

HARDWARE NOTES:

- HARDWARE TO BE LEVER ACTUATED PER ANSI A117.1
- CYLINDER OPERATION BY LEVER
- MAX. THRESHOLD HEIGHT 1/2"
- CLOSERS SHALL HAVE A 3 SECOND SWEEP FROM 70° OPEN POSITION TO 3° FROM LATCH.
- MAX DOOR OPENING FORCE 8.5 # PUSH/PULL
- INTERIOR DOOR HANDLES THROUGHOUT TO BE SARGENT ND LEVEL; COLOR TO BE BLACK SUEDE POWDER COAT. DOOR HARDWARE COLOR TO MATCH DOOR HANDLES
- DOOR HARDWARE SHALL NOT REQUIRE GRASPING, TIGHT PINCHING OR TWISTING OF WRIST TO OPERATE.

ABBREVIATION LEGEND

SCWD	SOLID-CORE WOOD
AL	ALUMINUM
HM	HOLLOW-METAL
WC	WOOD CASIED
PTD	PAINTED
PRF	PRE-FINISHED
GL	GLASS

WINDOW GENERAL NOTES

- LETTER 'S' ON GLAZING INDICATES LOCATION OF SAFETY GLAZING. SEE SCHEDULE FOR LOCATION. SAFETY GLASS TO COMPLY WITH IBC SECTIONS 2406 & 2407.
- LETTER 'F' ON SASHES INDICATES THAT IT IS FIXED.
- ALL GLAZING IN EXTERIOR WINDOWS TO BE LOW-E CLEAR GLAZING. BASIS OF DESIGN SOLARBAN 70 ON CLEAR 6MM (2) AIR 12" (12.7MM) CLEAR 6MM, SHGC 0.25
- FIRE RATED WINDOWS & GLASS TO COMPLY WITH IBC SECTION 716.6.
- ALL FRAMES TO BE BLACK ANODIZED ALUMINUM THERMALLY BROKEN.

WINDOW NOTES:

- ALL GLASS SHALL BE TEMPERED AS REQUIRED BY CODE ONLY
- ALL DOOR LITES AND INTERIOR GLAZING SHALL BE 1/4" CLEAR TEMPERED

EXTERIOR STOREFRONT TYPES

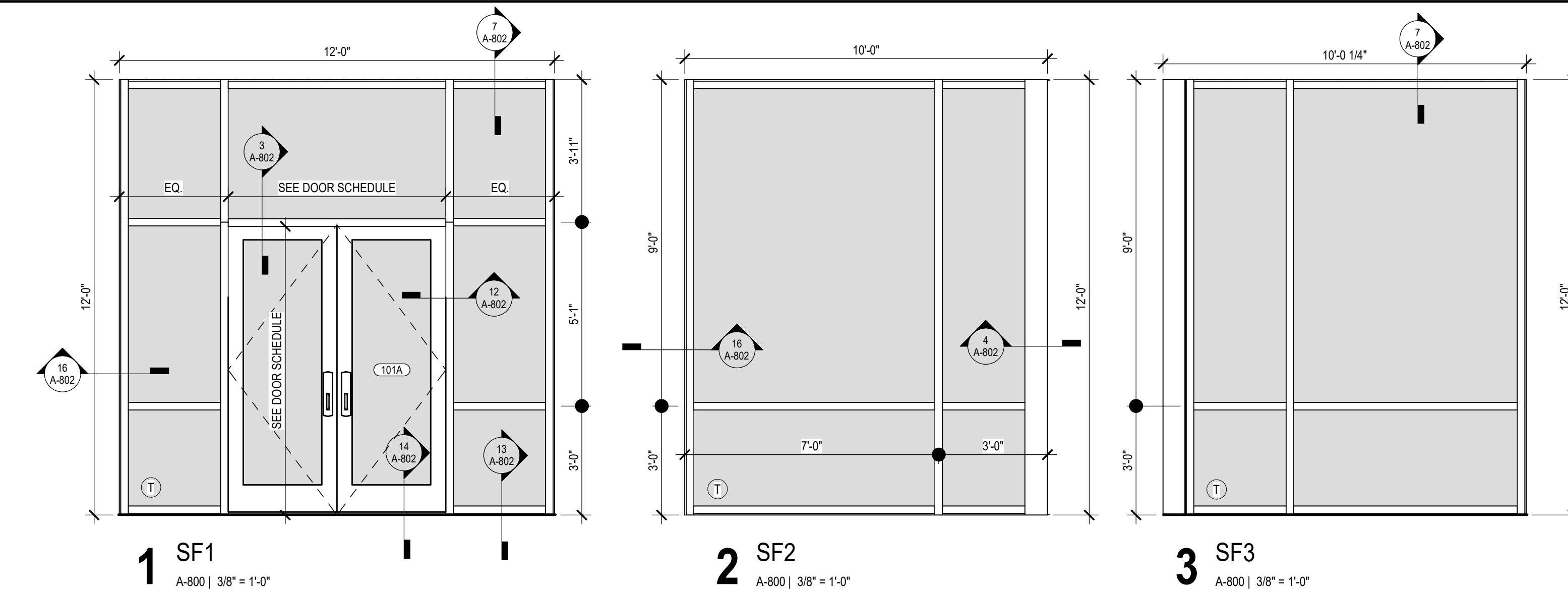

INTERIOR STOREFRONT TYPES

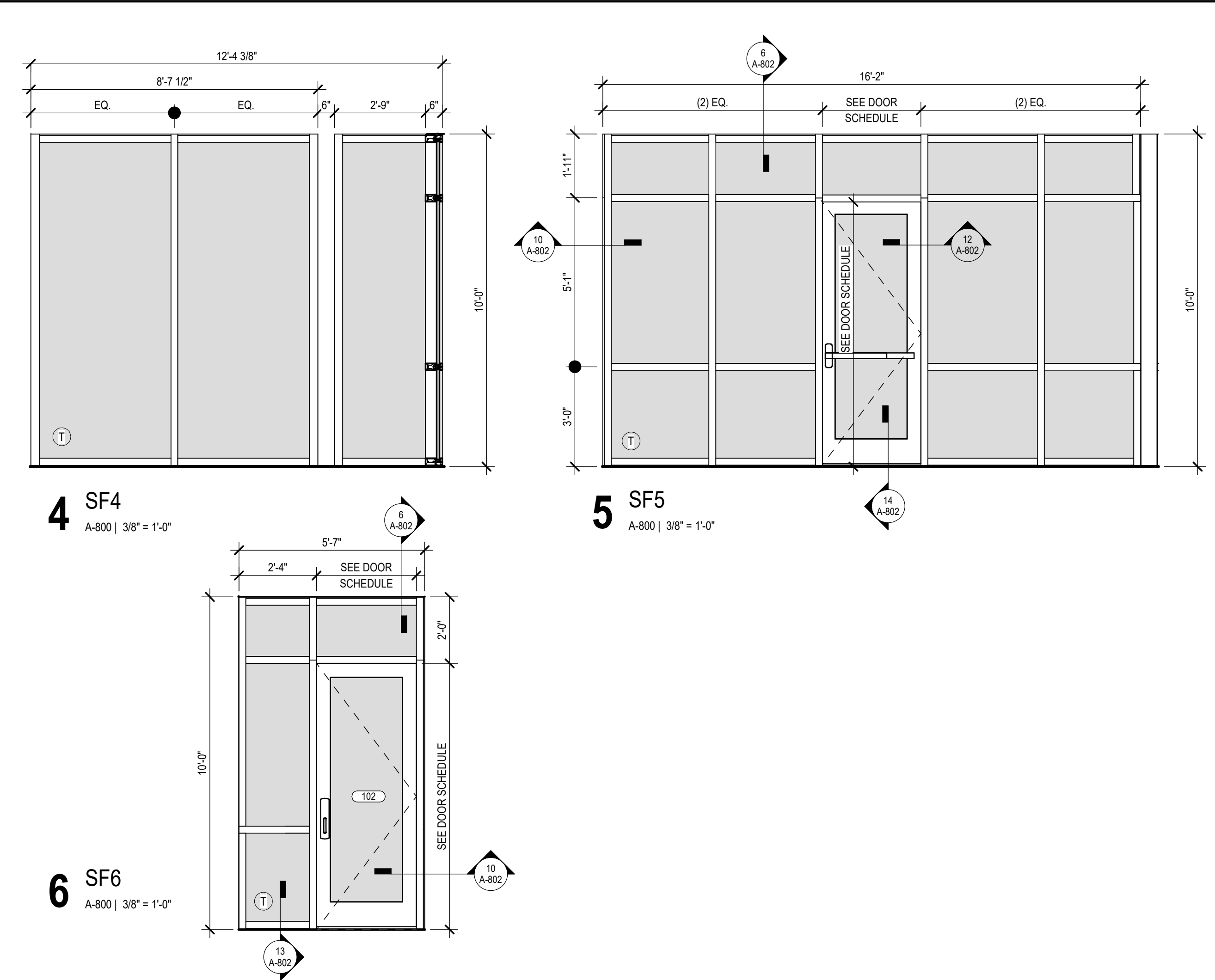

WINDOW TYPE

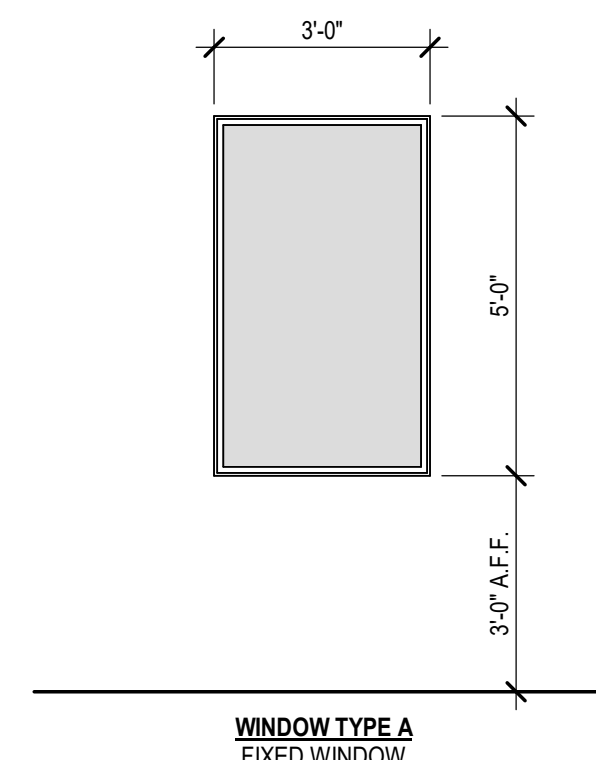

PRICING ONLY NOT FOR CONSTRUCTION

PROJECT NUMBER: 25-038

REVISIONS NO. DATE ISSUE

PEACH STATE CONSTRUCTION COMPANY OFFICE

PRICING ONLY NOT FOR CONSTRUCTION

DOOR AND FRAME ELEVATIONS & LEGEND

A-800

PRICING ONLY