

**PRICING ONLY NOT FOR CONSTRUCTION**

PROJECT NUMBER: 25-038

REVISIONS  
 NO. DATE ISSUE

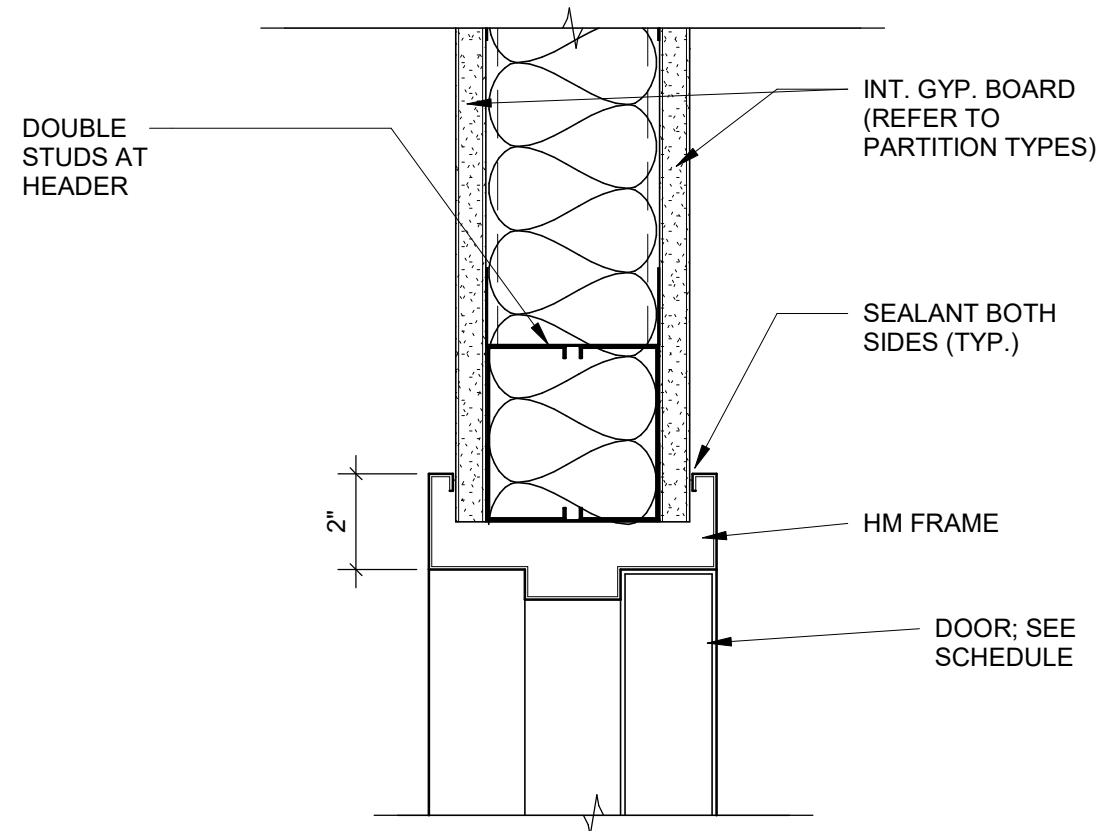

**1 HM TYP. DETAIL**  
 A-802 | 3" = 1'-0"

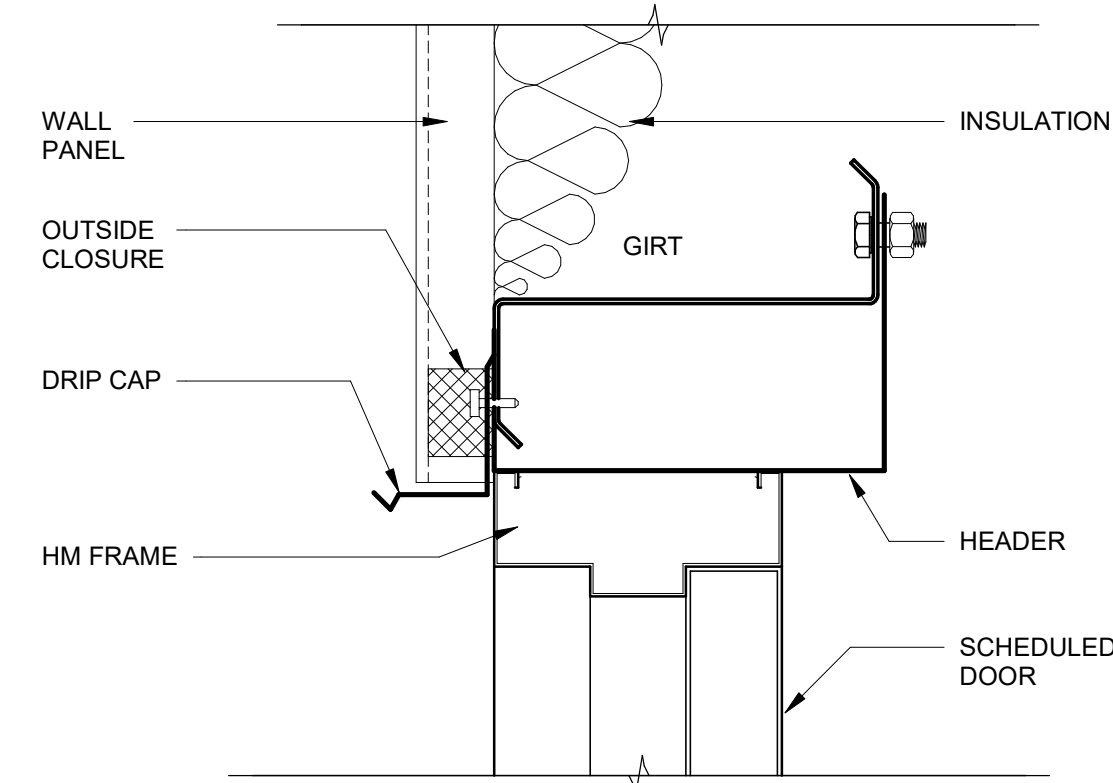

**2 MTL. PANEL HEAD**  
 A-802 | 3" = 1'-0"

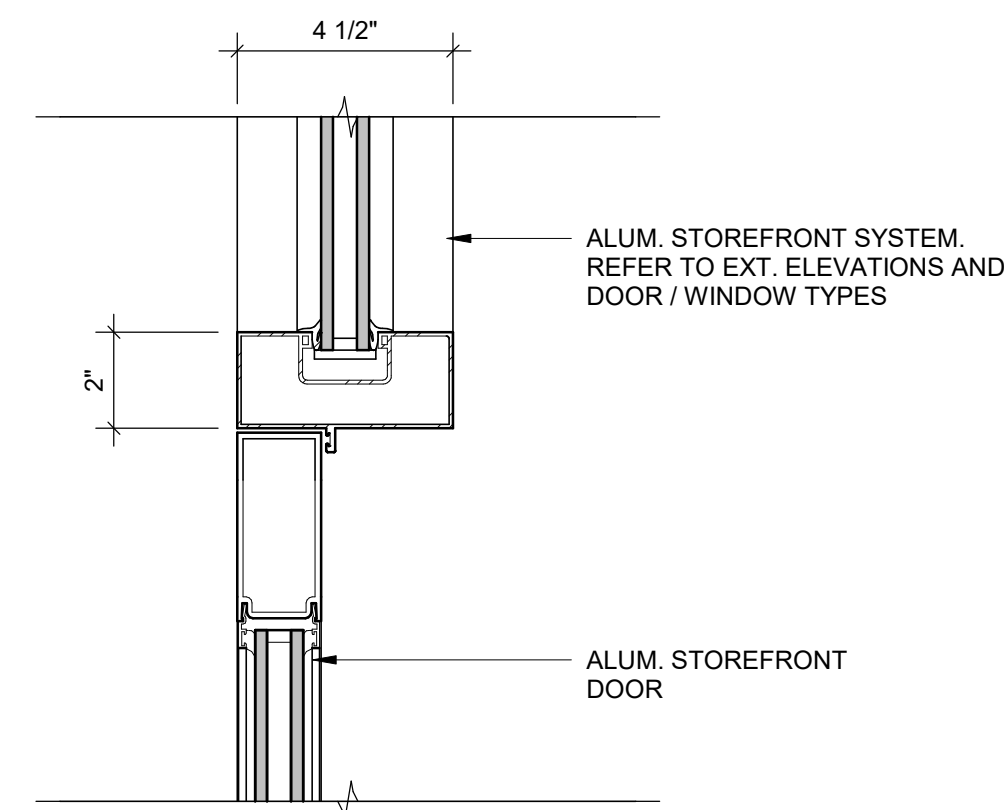

**3 STOREFRONT HEAD**  
 A-802 | 3" = 1'-0"

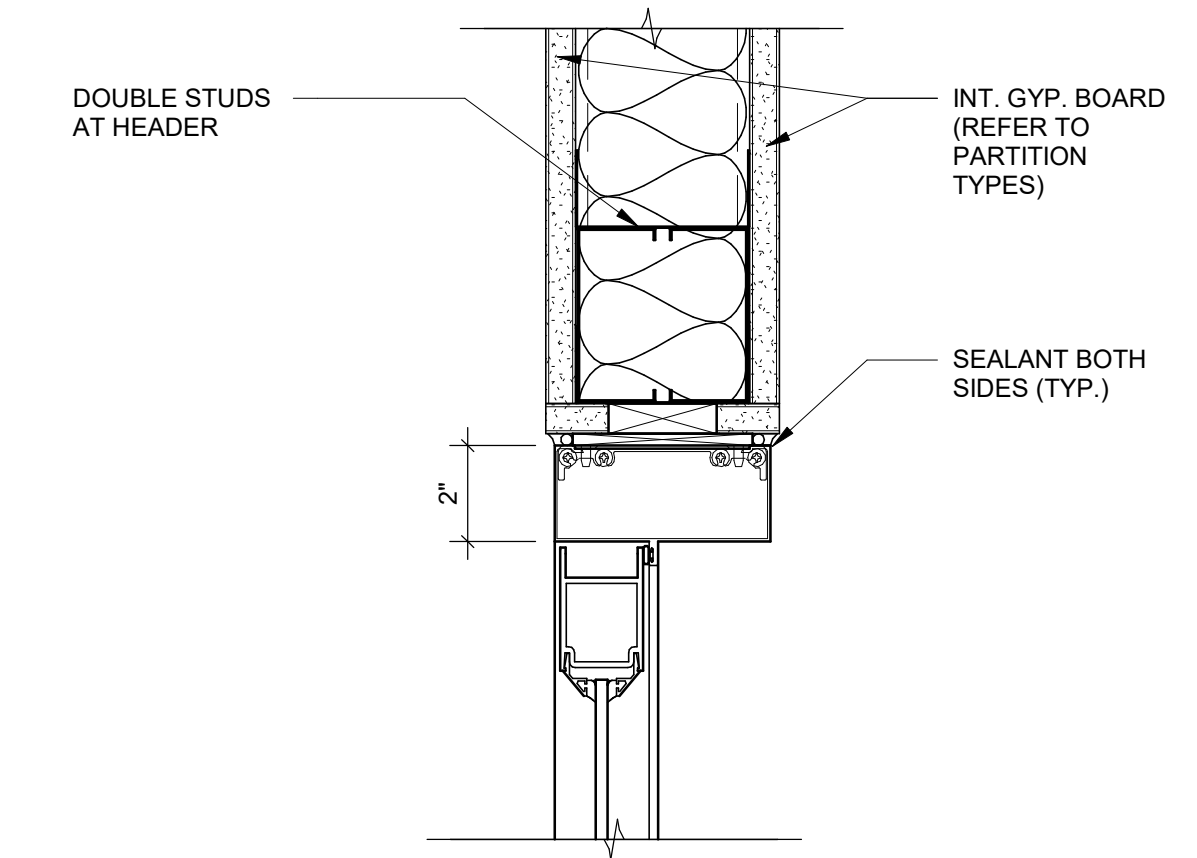

**4 ALUM. DOOR INT. HEAD**  
 A-802 | 3" = 1'-0"

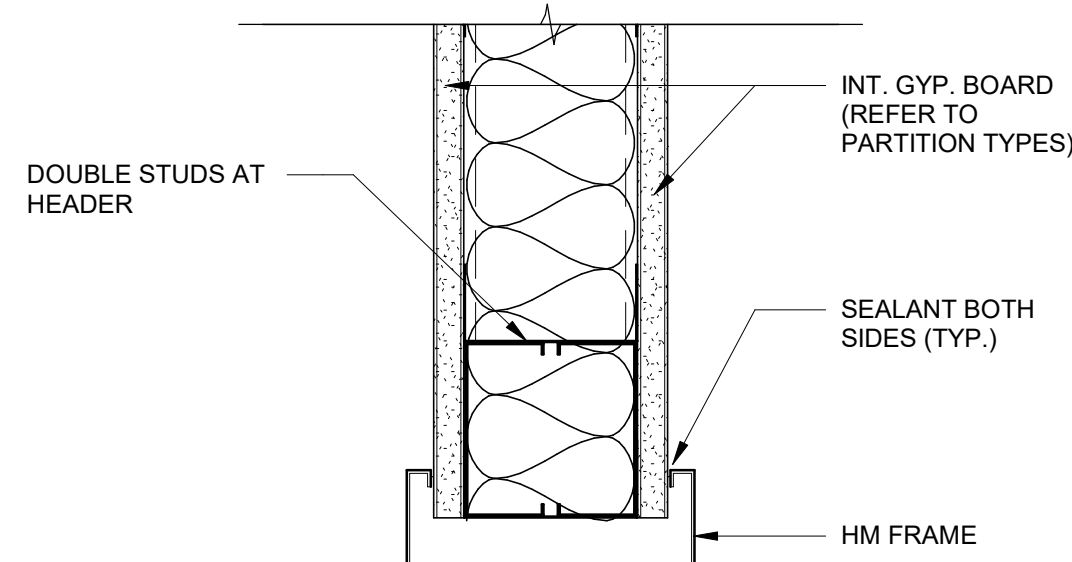

**5 HM CASSED HEAD**  
 A-802 | 3" = 1'-0"

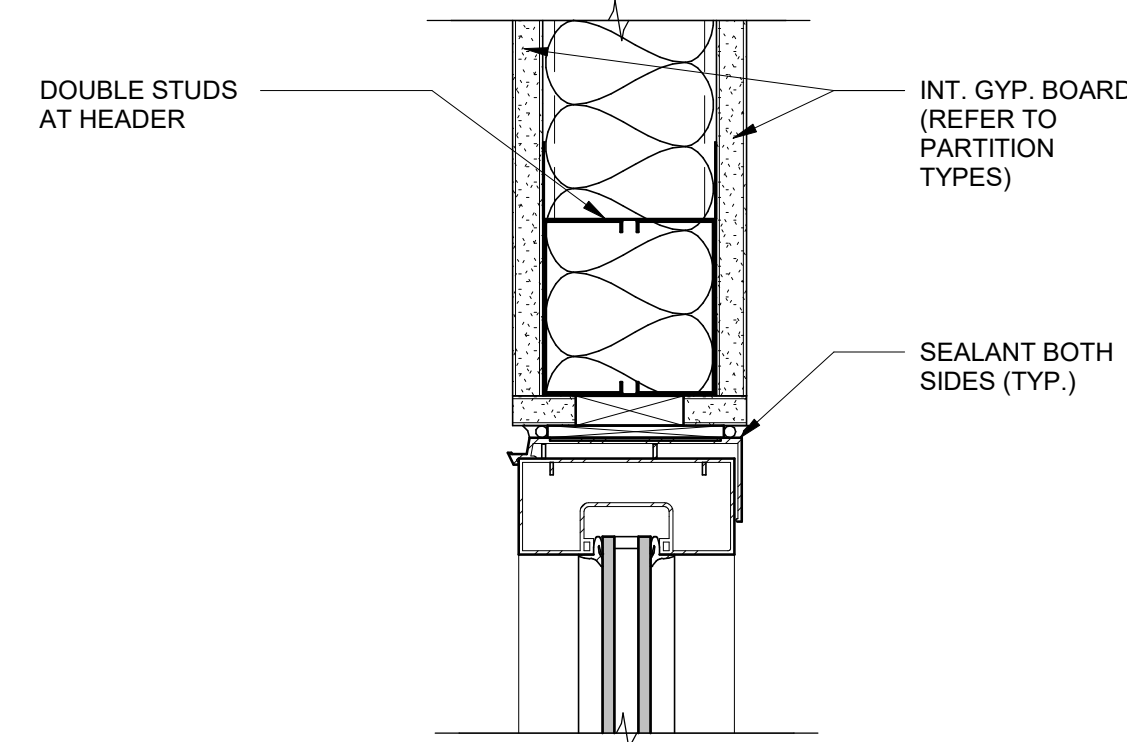

**6 ALUM. STOREFRONT INT. HEAD**  
 A-802 | 3" = 1'-0"

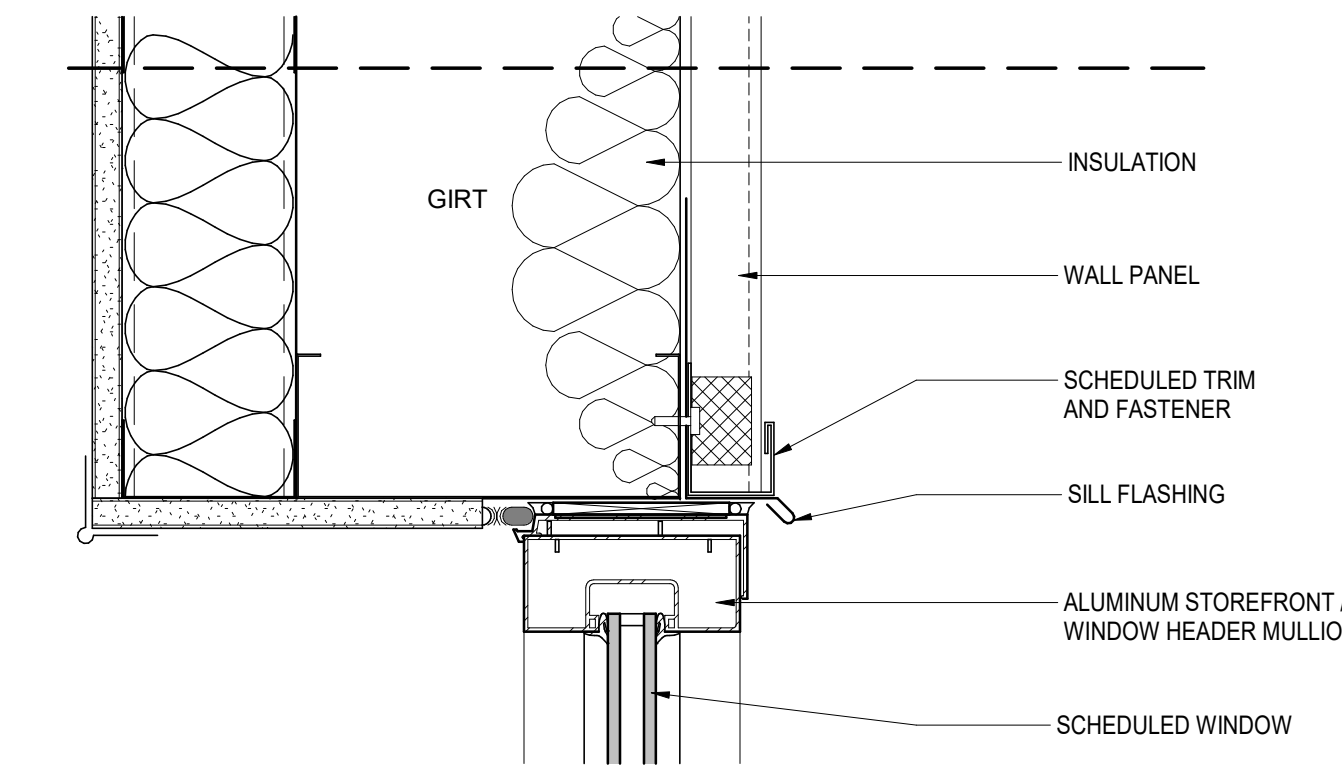

**7 WINDOW HEADER - METAL WALL PANEL**  
 A-802 | 3" = 1'-0"

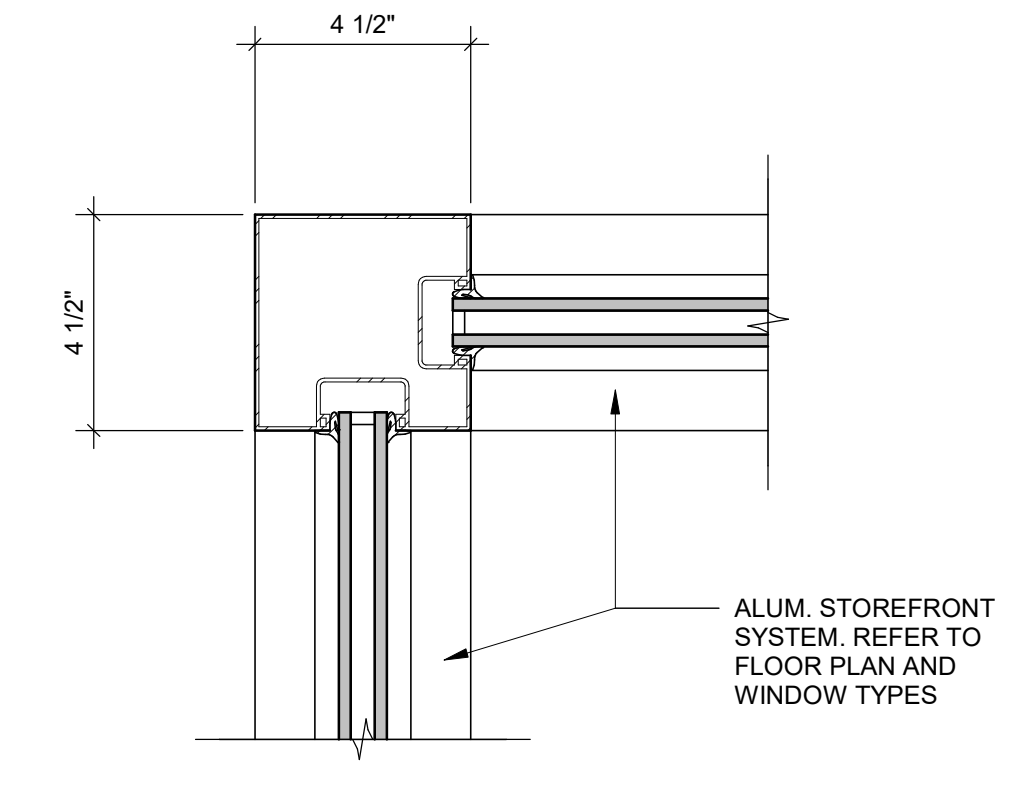

**8 CORNER STOREFRONT**  
 A-802 | 3" = 1'-0"

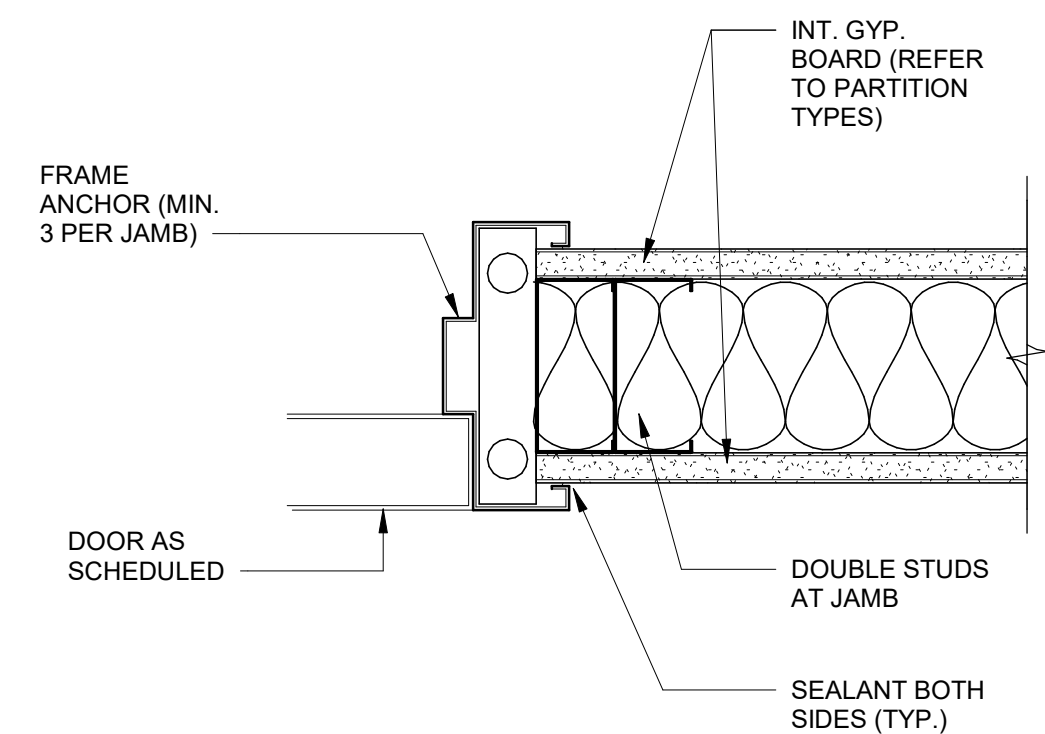

**9 HM TYP. JAMB**  
 A-802 | 3" = 1'-0"

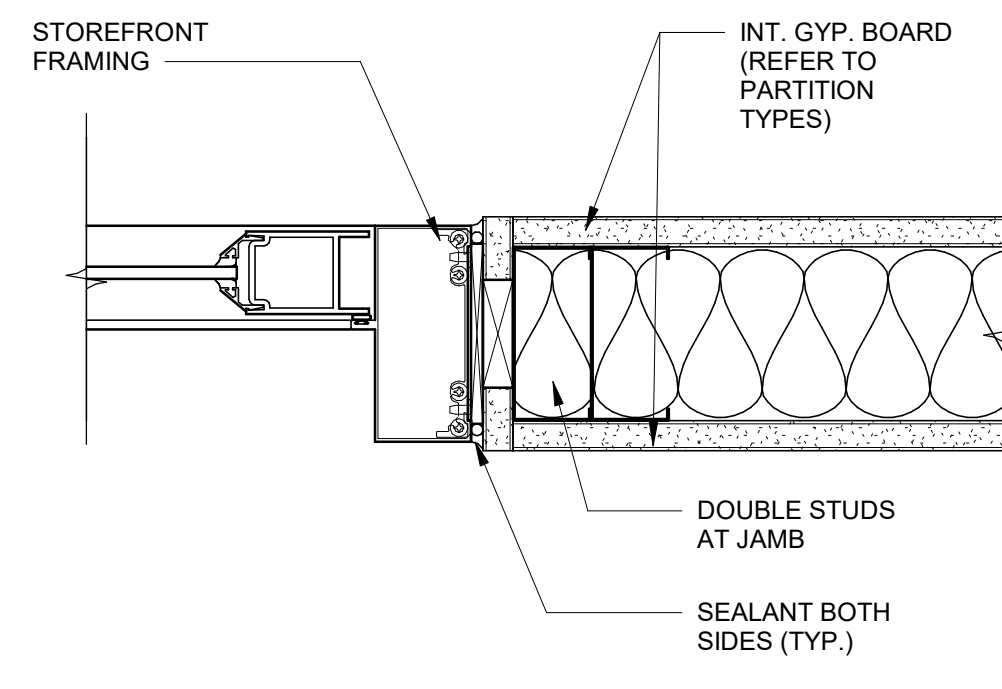

**10 ALUM. INT. JAMB**  
 A-802 | 3" = 1'-0"

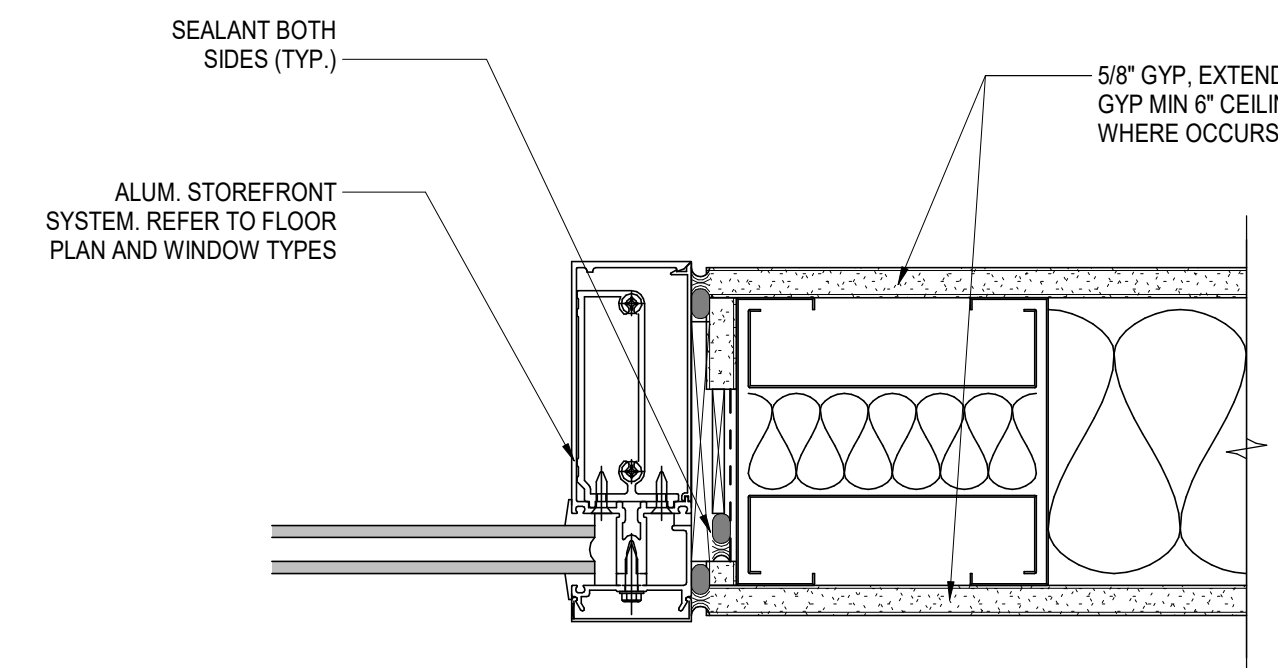

**11 STOREFRONT / WINDOW JAMB - GYP**  
 A-802 | 3" = 1'-0"

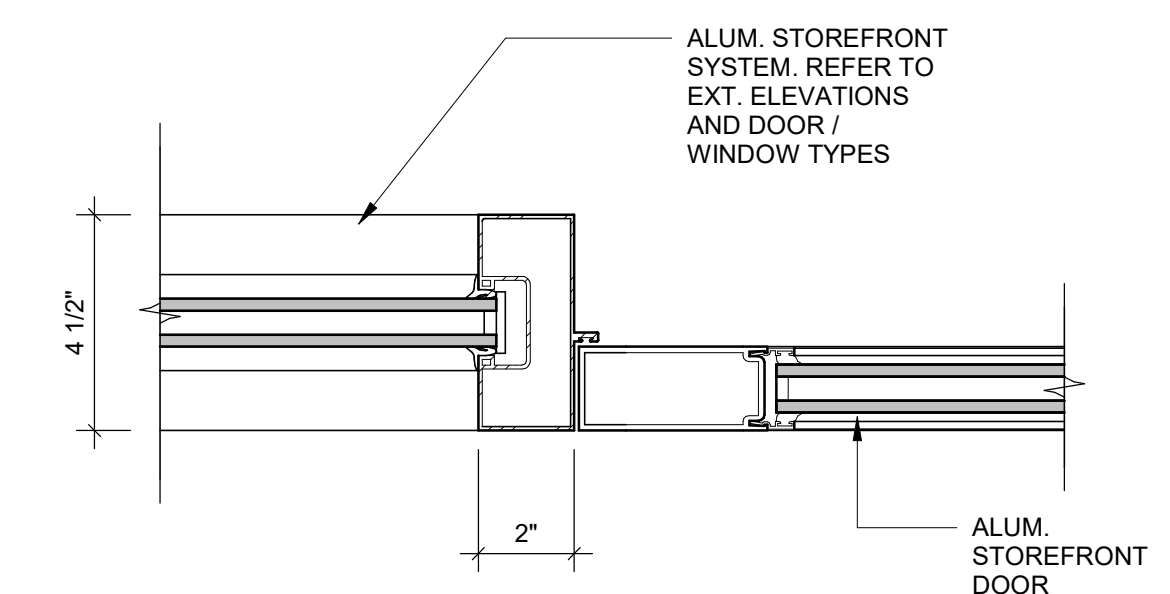

**12 STOREFRONT JAMB**  
 A-802 | 3" = 1'-0"

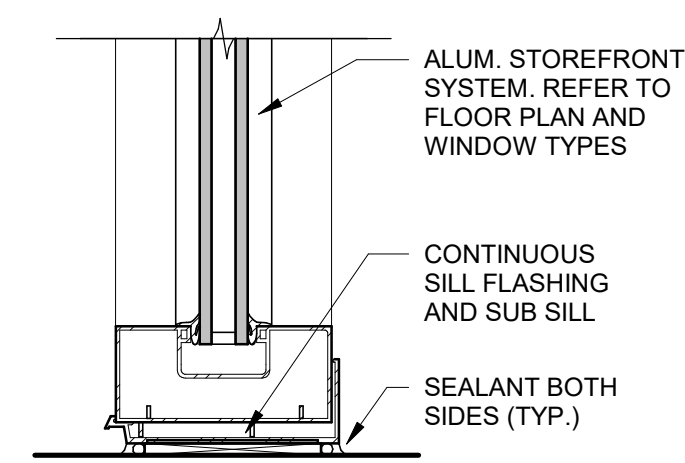

**13 SILL STOREFRONT**  
 A-802 | 3" = 1'-0"

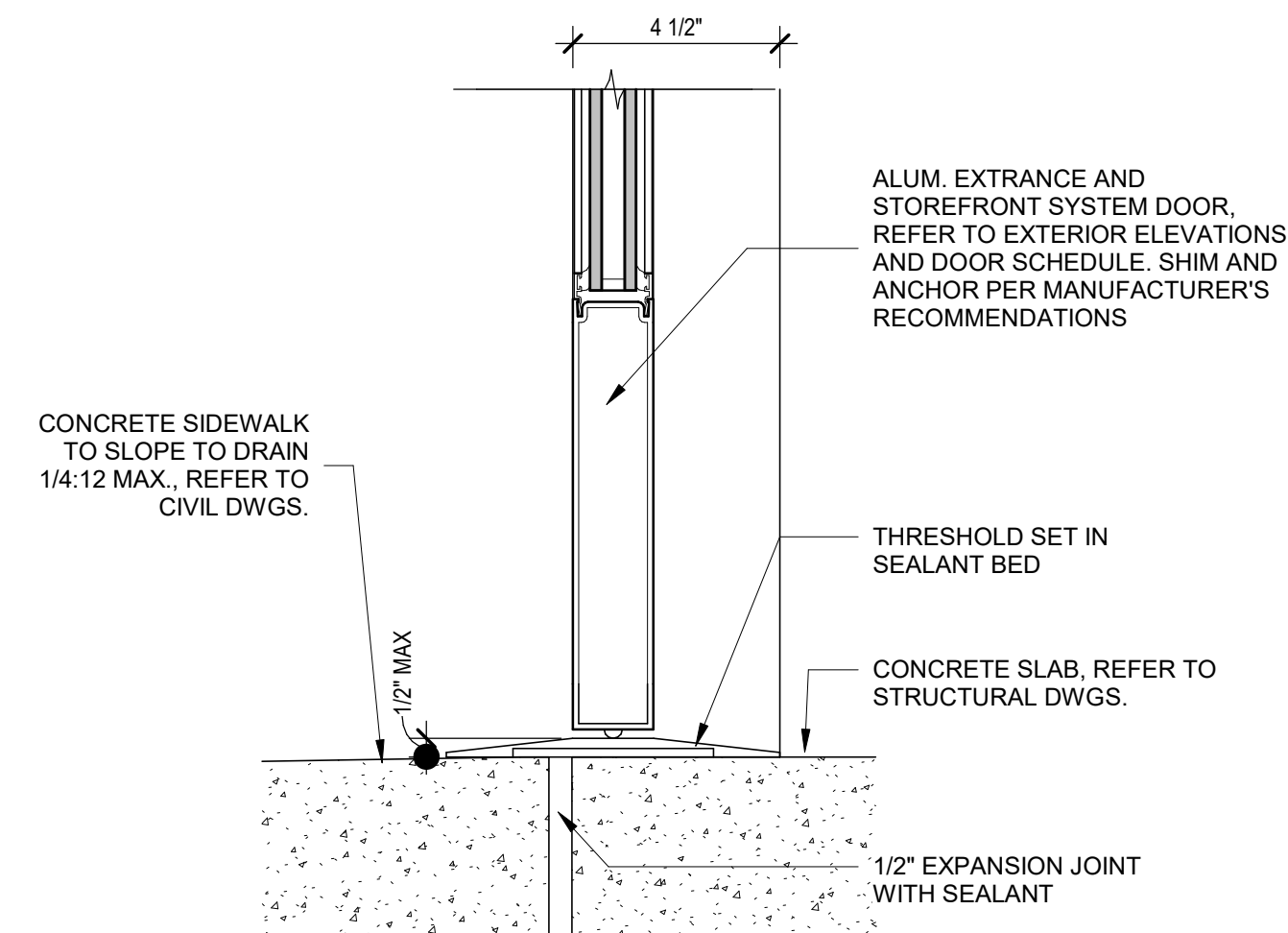

**14 SILL STOREFRONT DR**  
 A-802 | 3" = 1'-0"

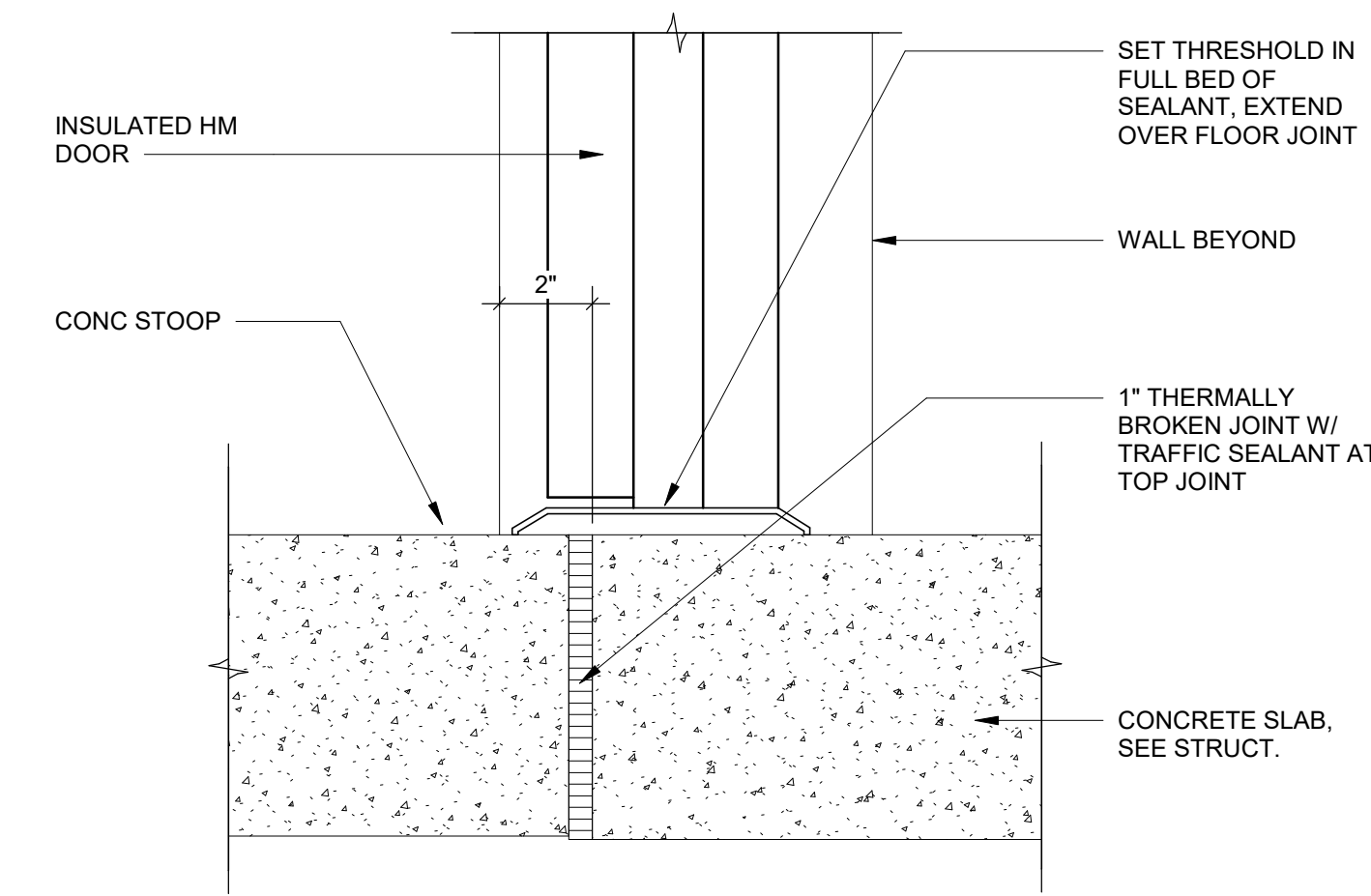

**15 HM DOOR SILL**  
 A-802 | 3" = 1'-0"

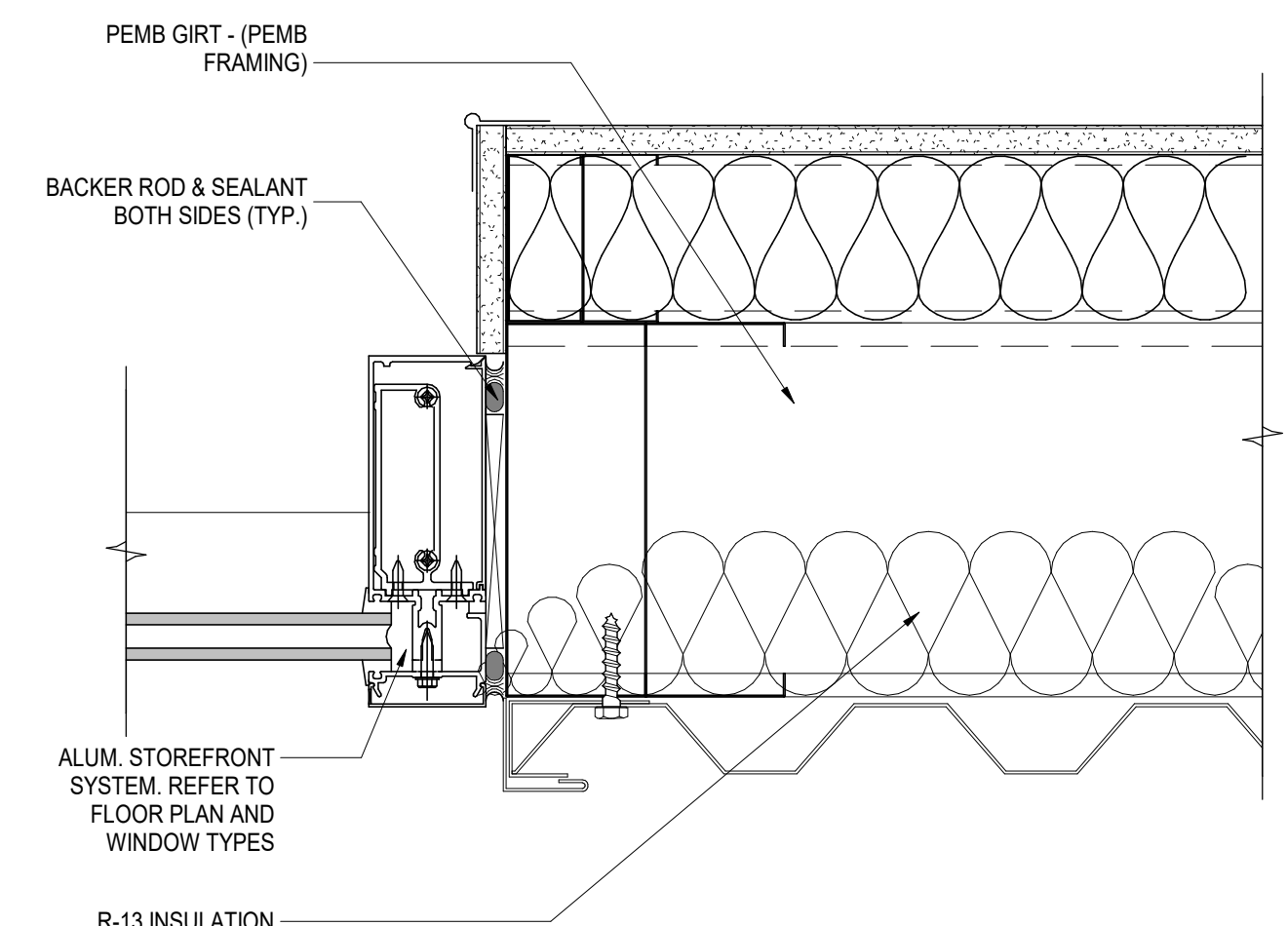

**16 STOREFRONT / WINDOW JAMB - PEMB**  
 A-802 | 3" = 1'-0"

**PEACH STATE CONSTRUCTION COMPANY OFFICE**

**PRICING ONLY NOT FOR CONSTRUCTION**

STOREFRONT HEAD & JAMB DETAILS

**A-802**

PRICING ONLY