

1 CONDENSATE DRAIN DETAIL  
 M0.5 NOT TO SCALE

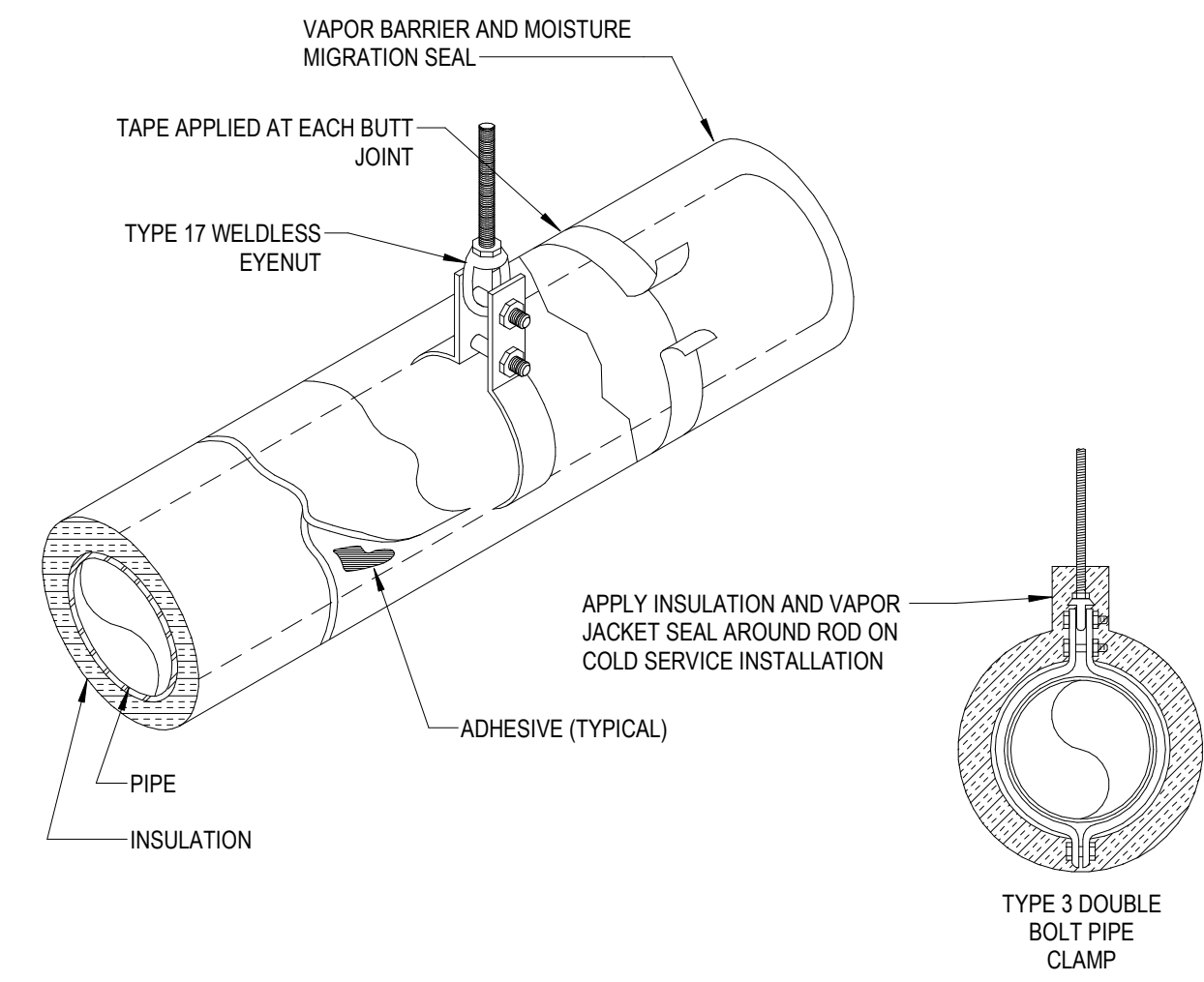

2 PIPE HANGER, INSULATION AND VAPOR JACKET  
 M0.5 NOT TO SCALE

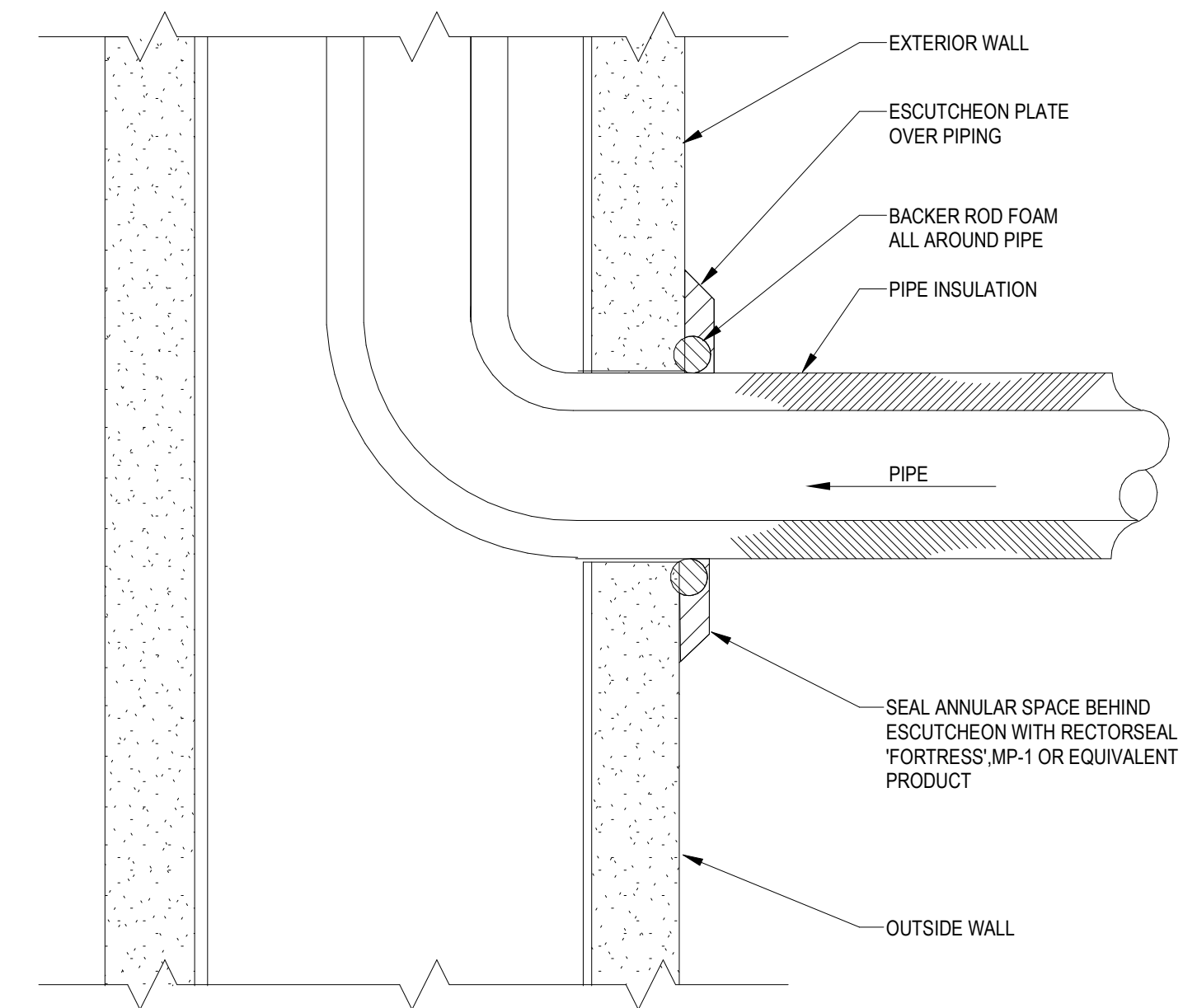

3 REFRIGERANT PIPE SLEEVE THROUGH WALL DETAIL  
 M0.5 NOT TO SCALE

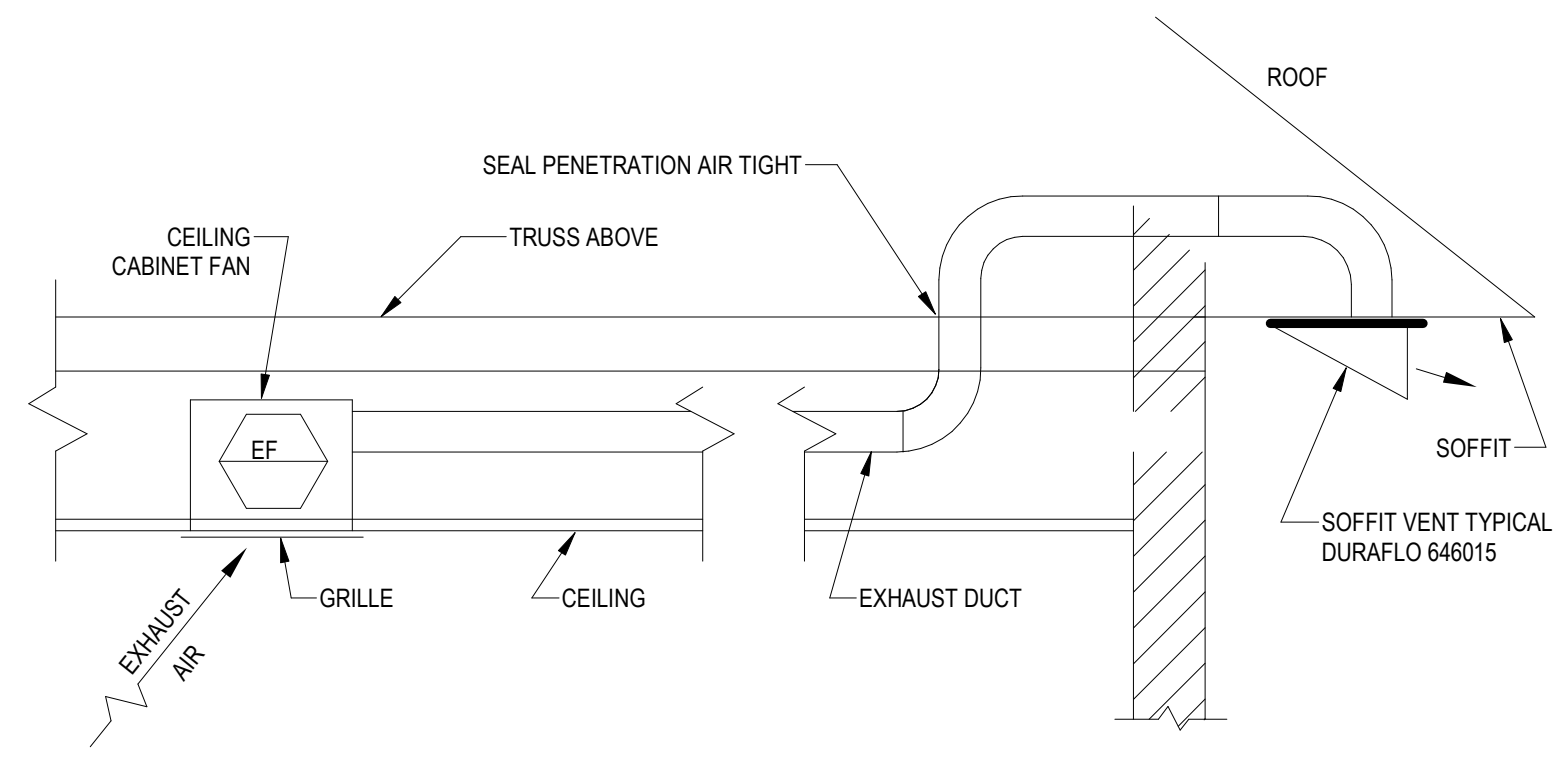

4 CEILING EXHAUST FAN WITH SOFFIT DISCHARGE-DETAIL  
 M0.5 NOT TO SCALE

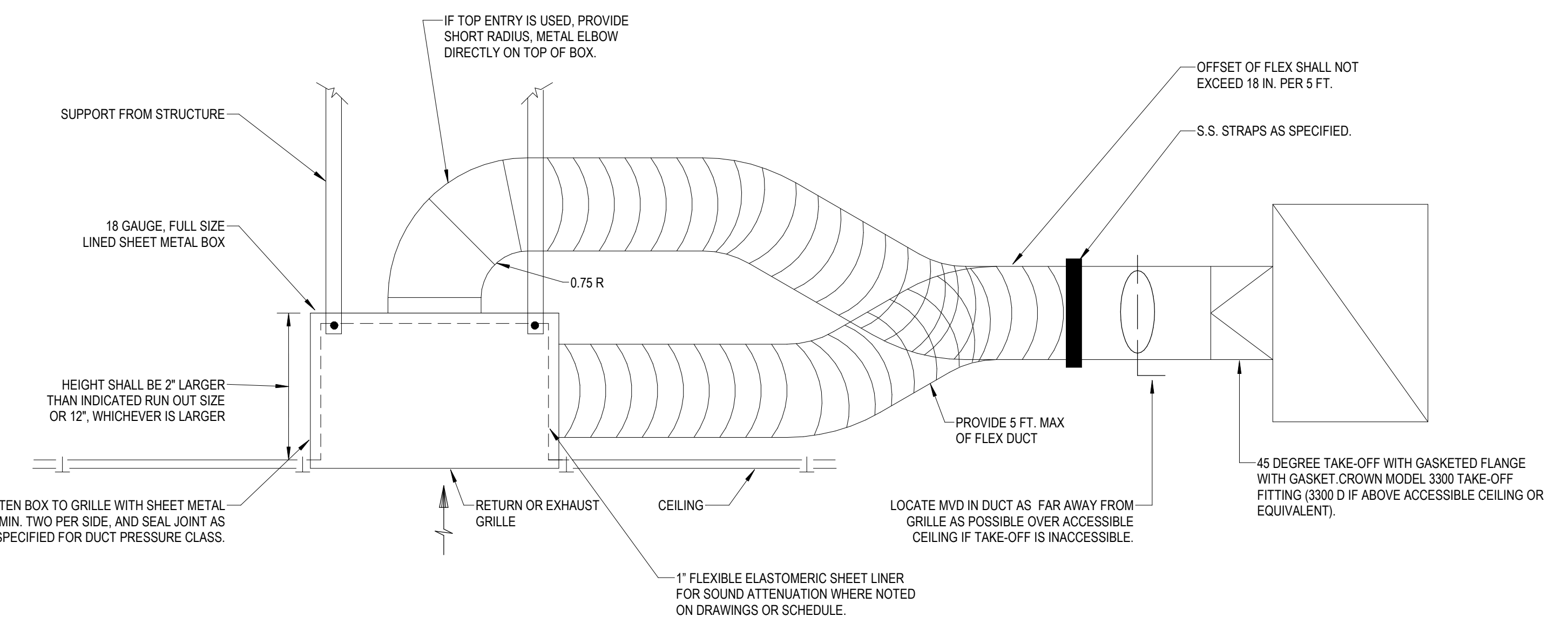

5 DETAIL AT TYPICAL GENERAL RETURN AND EXHAUST GRILLE - LINED  
 M0.5 NOT TO SCALE

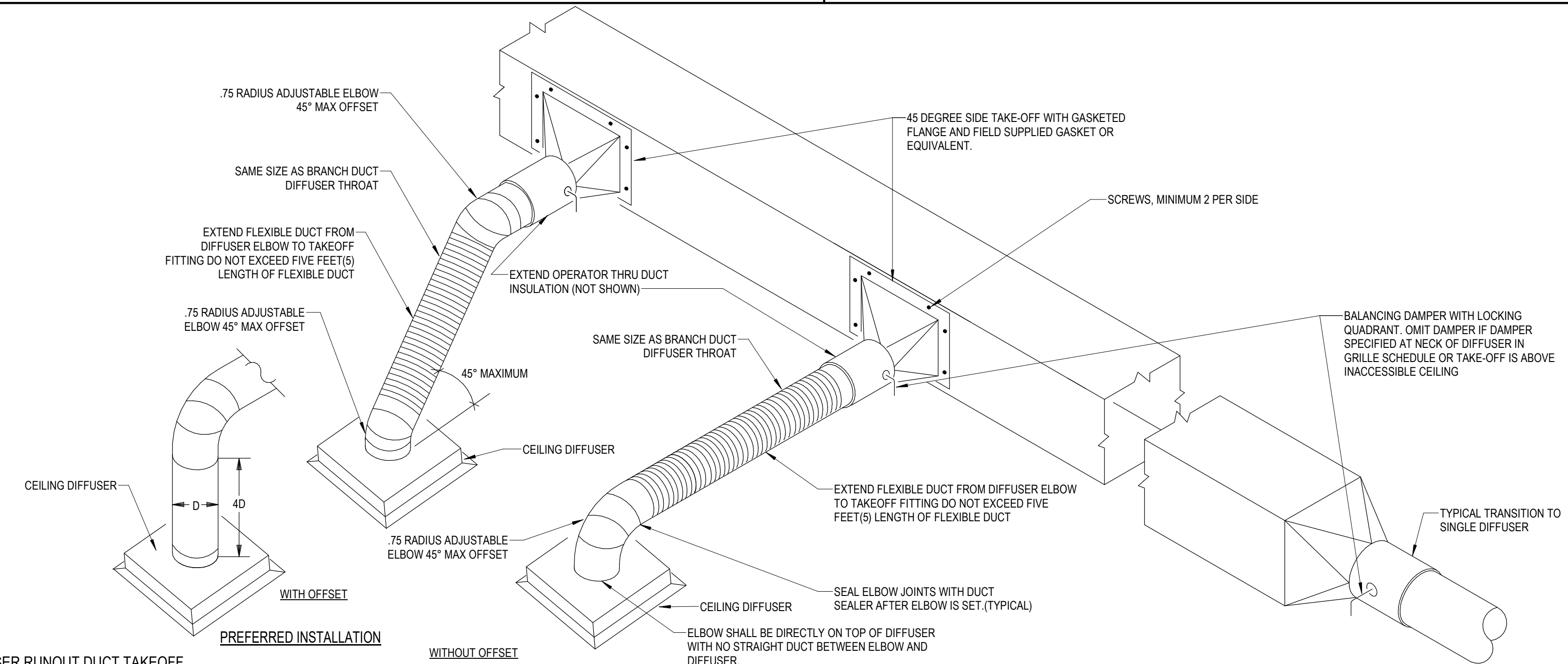

6 DIFFUSER RUNOUT DUCT TAKEOFF  
 M0.5 NOT TO SCALE

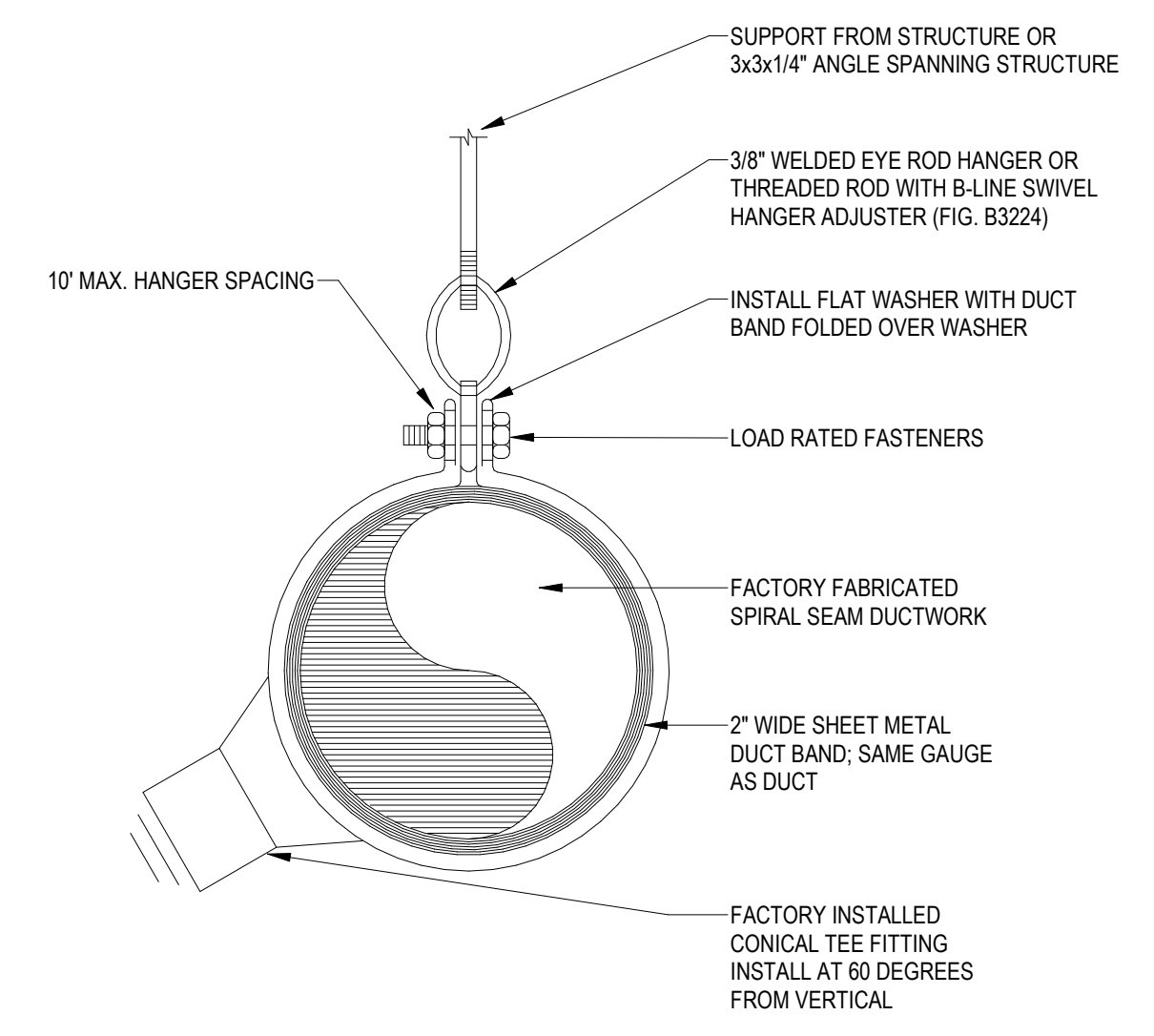

7 DUCT SUPPORT IN EXPOSED AREA  
 M0.5 NOT TO SCALE