

#	DATE	TITLE

PROJECT NUMBER:
00-000

1167 PACE ST. - PHASE I
1167 PACE ST, COVINGTON, GA

SECTIONS & DETAILS

S301

THIS DRAWING AND THE FILE FROM WHICH IT HAS BEEN CREATED ARE AN INSTRUMENT OF SERVICE FOR THIS PROJECT. THESE DOCUMENTS ARE THE SOLE PROPERTY OF THE ARCHITECT, AND ANY USE OF THESE DOCUMENTS FOR PURPOSES OTHER THAN THOSE ASSOCIATED WITH THIS PROJECT IS STRICTLY PROHIBITED.

NOT RELEASED FOR CONSTRUCTION

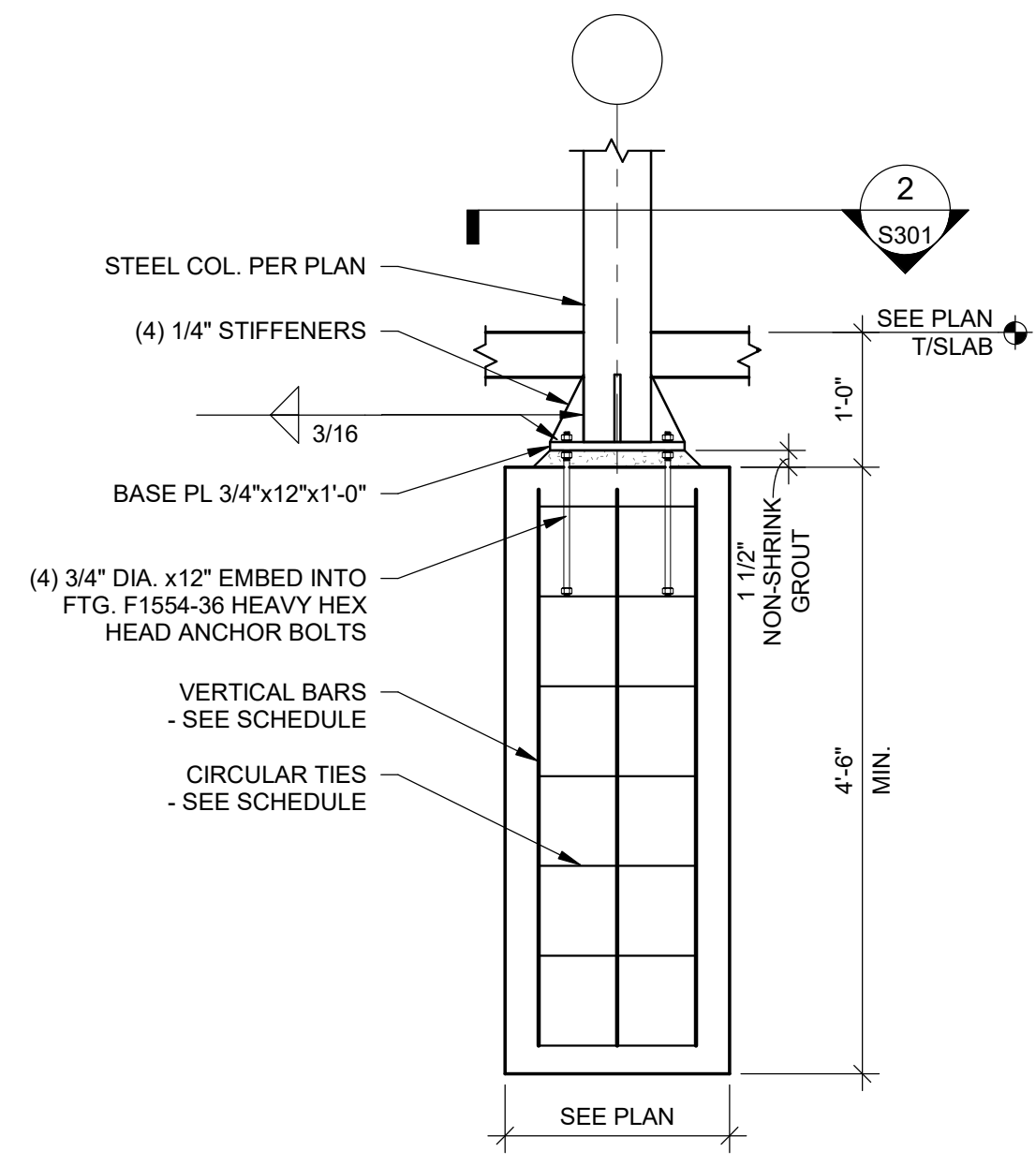

1 SECTION
S301 SCALE: 3/4" = 1'-0"

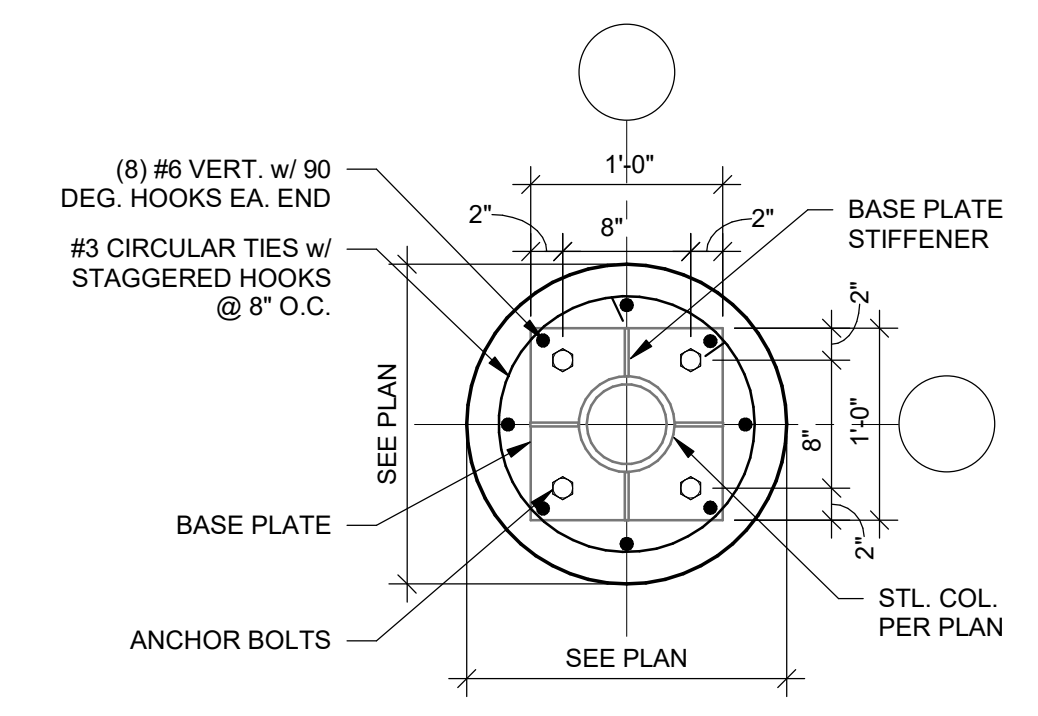

2 SECTION
S301 SCALE: 1" = 1'-0"

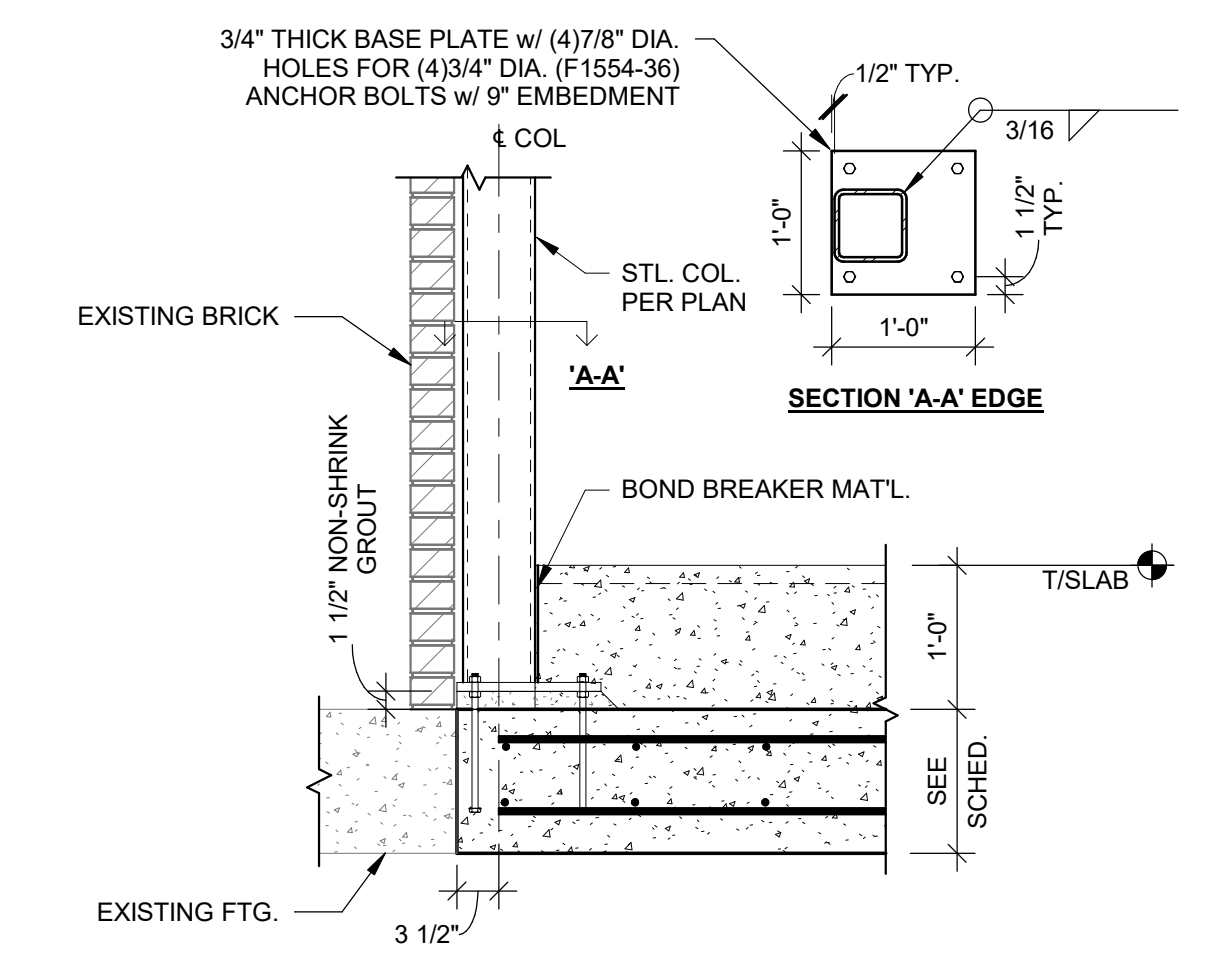

3 SECTION
S301 SCALE: 3/4" = 1'-0"

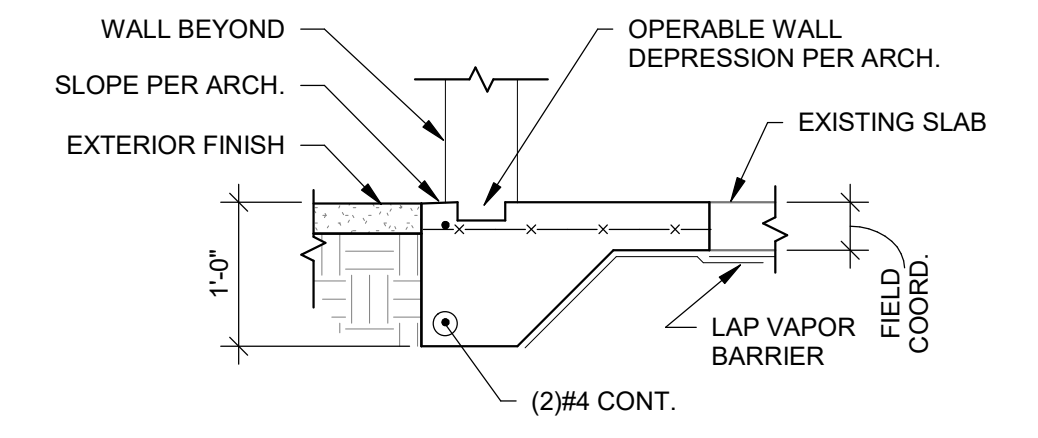

4 SECTION
S301 SCALE: 3/4" = 1'-0"

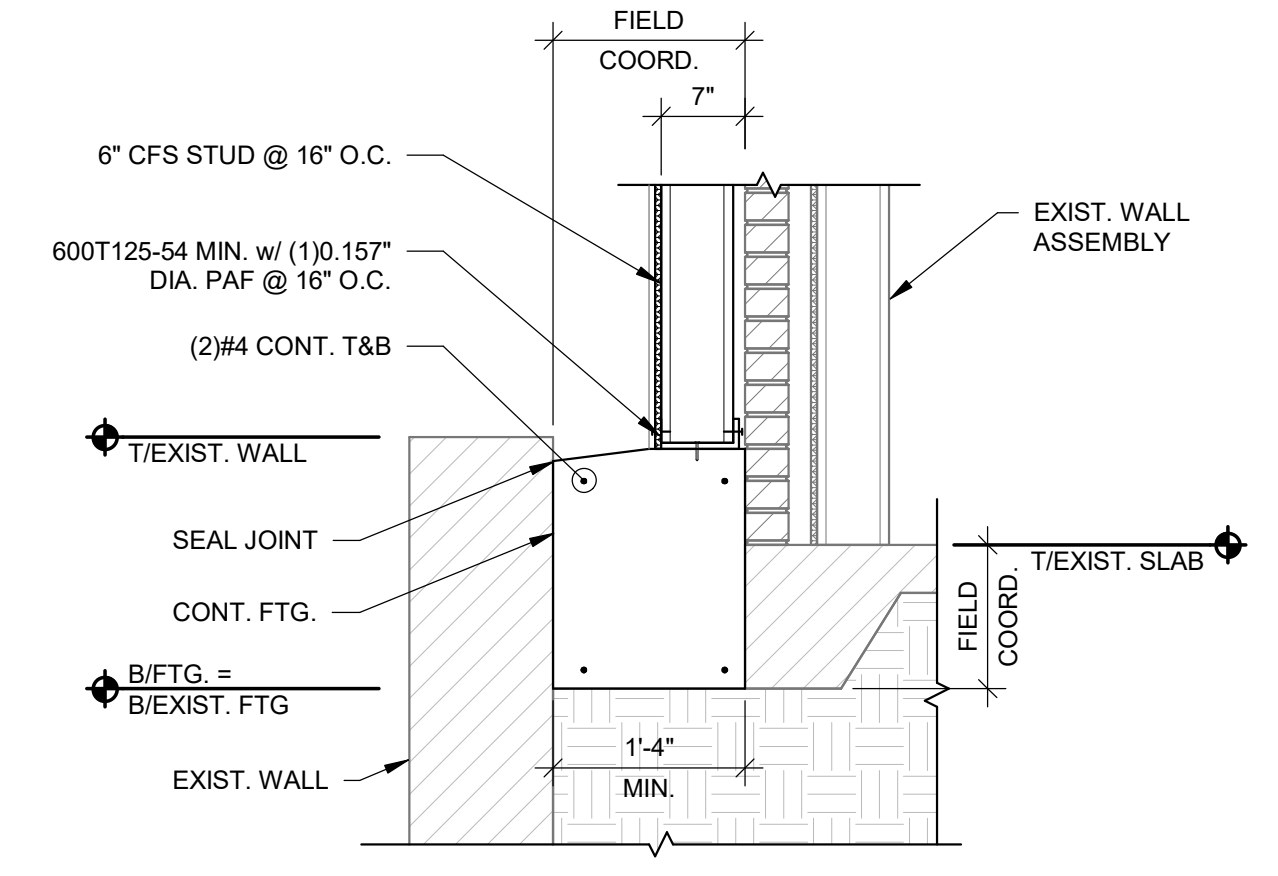

5 SECTION
S301 SCALE: 3/4" = 1'-0"

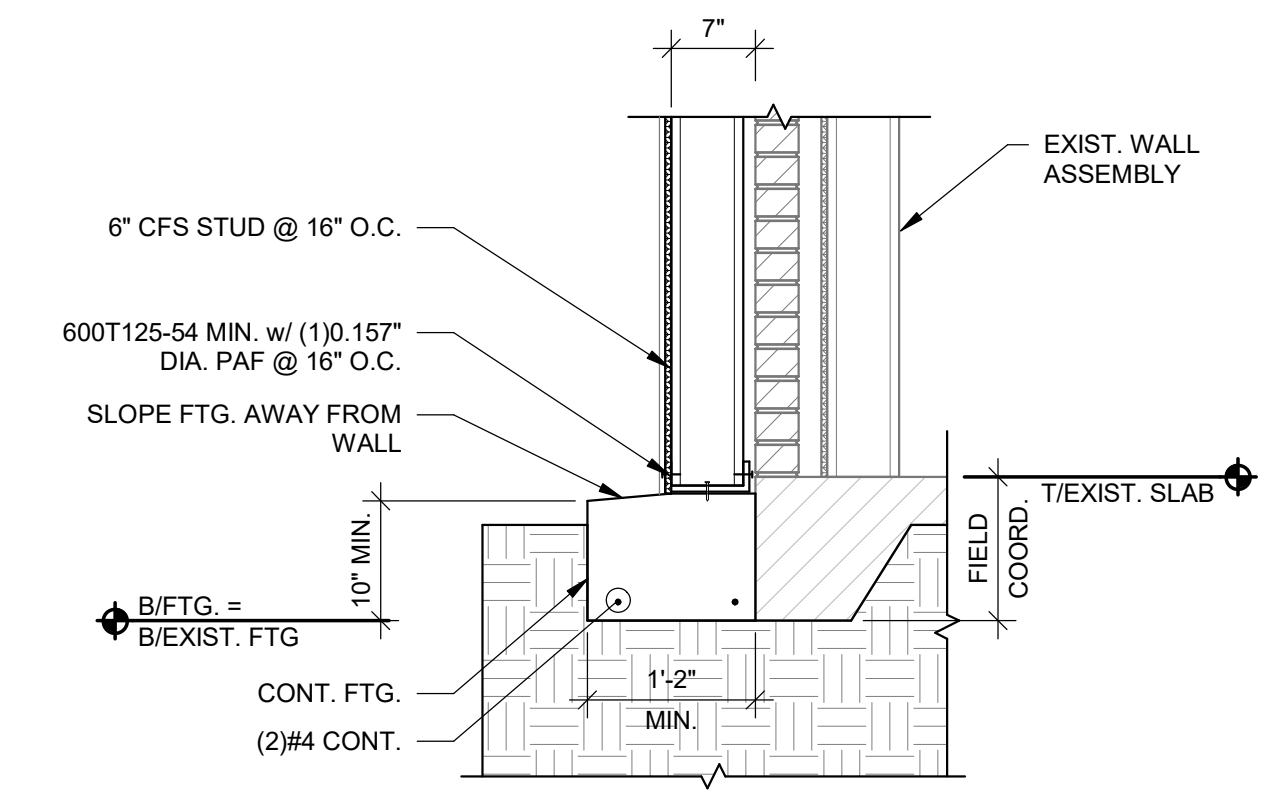

6 SECTION
S301 SCALE: 3/4" = 1'-0"

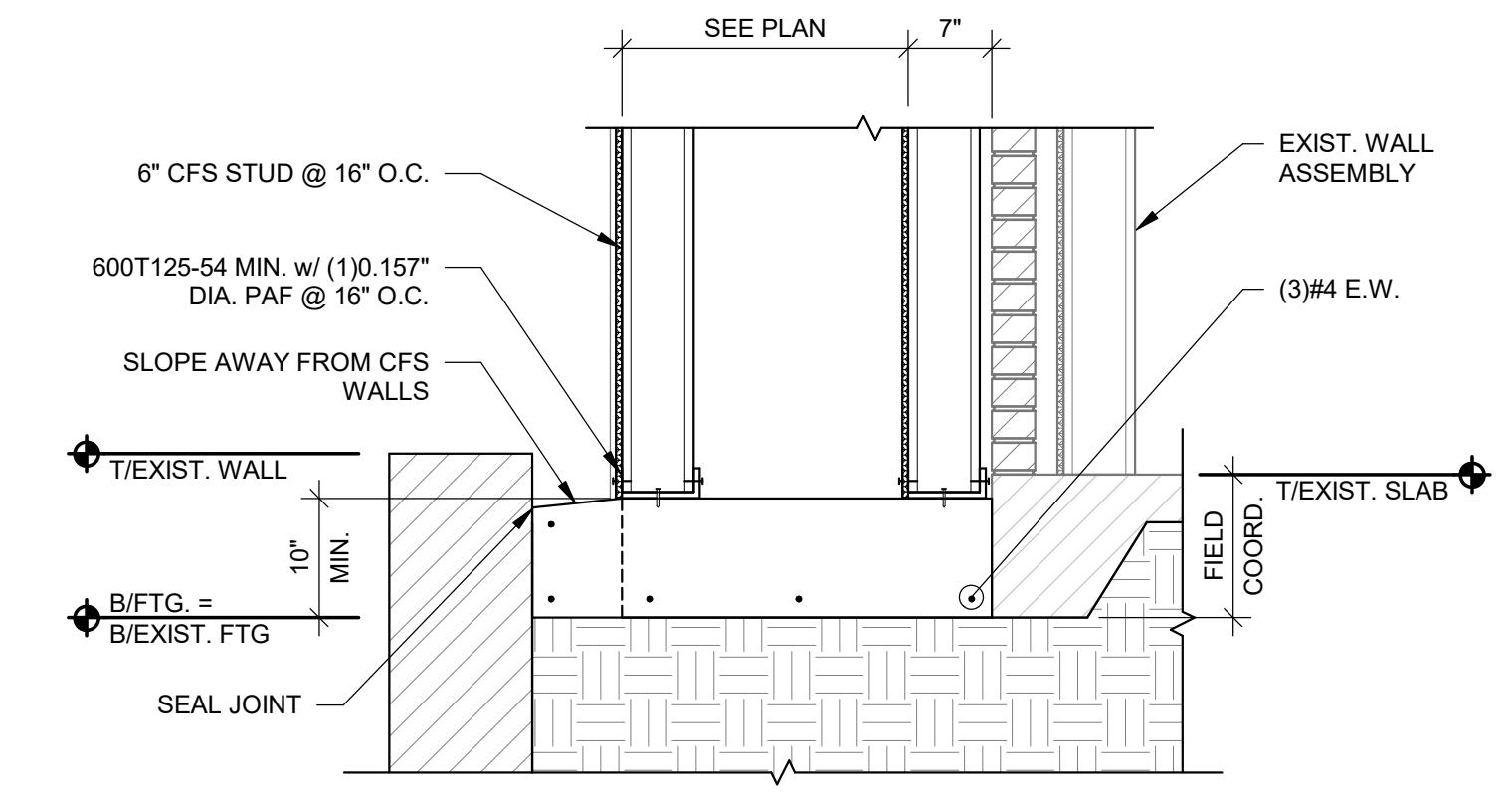

7 SECTION
S301 SCALE: 3/4" = 1'-0"